



Wire Harness Installation Instructions

For Installing:

**Part #20120
22 Circuit Ford Mustang (1965- 1966)**

Manual #90526



Perfect Performance Products, LLC

Painless Performance Products Division

2501 Ludelle Street

Fort Worth, TX 76105-1036

800-423-9696 phone – 817-244-4024 fax

Web Site: www.painlessperformance.com

E-Mail: painless@painlessperformance.com

If you have any questions concerning the installation of this harness or having trouble in general, feel free to call Painless Performance Products' tech line at 1-800-423-9696. Calls are answered from 8am to 5pm central time, Monday thru Friday, except holidays.

We have attempted to provide you with as accurate instructions as possible, and are always concerned about corrections or improvements that can be made. If you have found any errors or omissions, or if you simply have comments or suggestions concerning these instructions, please write us at the address on the cover and let us know about them. Or, better yet, send us a fax at (817) 244-4024 or e-mail us at painless@painlessperformance.com. We sincerely appreciate your business.

Perfect Performance Products, LLC shall in no event be liable in contract or tort (including negligence) for special, indirect, incidental, or consequential damages, such as but not limited to, loss of property damage, or any other damages, costs or expenses which might be claimed as the result of the use or failure of the goods sold hereby, except only the cost of repair or replacement.

P/N 90526 Painless Wiring Manual

June 2009

Copyright © 2003 by Perfect Performance Products, LLC

CAUTION: BEFORE THE REMOVAL OF YOUR ORIGINAL HARNESS AND/OR THE INSTALL OF YOUR NEW PAINLESS HARNESS, DISCONNECT THE POWER FROM YOUR VEHICLE BY REMOVING THE NEGATIVE OR POSITIVE BATTERY CABLE FROM THE BATTERY. UNDER NO CIRCUMSTANCES SHOULD THE BATTERY BE CONNECTED UNTILL THE PAINLESS HARNESS HAS BEEN INSTALLED AND TESTED. See "TESTING THE SYSTEM"

- A full color copy of these instructions can be found at <http://www.painlessperformance.com/InfoSearch/manuals.php>
- If your vehicle has an existing harness, you will want to retain it for the possible re-use of various pigtails & connector housings particular to your application. During the removal process, avoid making any unnecessary cuts and label all connectors as they are disconnected. Included in this kit as a sheet of pre-printed labels, to assist in identifying connections as they are removed from the vehicle. It's a good idea to document how the original harness is routed as this Painless harness follows most of the same routing.
- Retain Convertible Power Top, Rally Pack, and Console wiring. Provisions for these options are not included in this kit.
- If you do not have an existing harness, the package of terminals included with the harness will enable you to make most of the connections needed.
- Painless Performance Products recommends you, the installer, read this installation manual from front to back before installing this harness. Due to the variables in modifications that can be done to Mustangs, reading this manual will give you considerable insight on the proper installation of this harness.
- Only printed wires will have a 900-series number. These 900-series numbers are used to identify various wires and circuits in the wiring diagrams that are a part of these instructions. The majority of those without a number are pre terminated with a connector installed.
- In the event that there are unused or unconnected wires, the ends of all wires labeled in this instruction manual as "POWER" or wires printed with "B+" in the description, will need to have the ends terminated with an insulated terminal or taped. Doing so will prevent the wires shorting and causing harness failure or fire.

5	<u>INTRODUCTION</u>
5	<u>CONENTS OF THE PAINLESS KIT</u>
6	<u>TOOLS NEEDED</u>
6	<u>PRE-INSTALLATION & ROUTING</u>
7	<u>GENERAL INSTALLATION</u>
9	<u>HARNESS ATTACHMENT</u>
10	<u>GROUNDING</u>
10	<u>TERMINAL INSTALLATION & MAKING CONNECTIONS</u>
11	<u>RE-USING-FACTORY CONNECTORS</u>
12	<u>SPECIFIC CIRCUIT CONNECTIONS</u>
12	<u>HEADLIGHT SECTION B</u>
	<u>ENGINE SECTION</u>
16	MAXI FUSE
16	IGNITION, START/RUN SYSTEM
19	BLOWER MOTOR
19	NEUTAL SAFETY/REVERSE SWITCH
	<u>INTERIOR</u>
19	TURN SIGNAL SWITCH
20	IGNITION SWITCH
20	INTERIOR LIGHTING
22	BRAKE SWITCH
22	INSTRUMENT PANEL
24	WIPER SWITCH
26	HAZARD SWITCH
26	HEATER, A/C WIRING
28	COOLING FAN SWITCH
30	HEADLIGHT SWITCH
30	DIMMER SWITCH
30	ACCESSORY RELAY
32	<u>TAIL SECTION</u>
33	<u>TESTING THE SYSTEM</u>
34	<u>FUSE REQUIREMENTS & WIRE INDEX</u>
40	<u>OTHER PAINLESS PARTS</u>

LIST OF FIGURES

6	FIGURE 1	Contents of the Painless Kit
8	FIGURE 2	Fuse Block Base Mounting
8	FIGURE 3	Fuse Block Positioning
9	FIGURE 4	Pass Through Plates
11	FIGURE 5	Terminal Locking Tang
11	FIGURE 6	Removing Factory Connector
12	FIGURE 7	Jaw Style Crimpers
13	FIGURE 8	Headlight Section B
14	FIGURE 9	Factory Alternator
16	FIGURE 10	Maxi Fuse Components
16	FIGURE 11	Ballast Resistor
17	FIGURE 12	Starting System
17	FIGURE 13	Factory Ignition
18	FIGURE 14	Internally Resisted Coil
18	FIGURE 15	MSD Connections
20	FIGURE 16	GM Column Connector
20	FIGURE 17	Ignition Switch Pin Out
21	FIGURE 18	Interior Lighting Schematic
23	FIGURE 19	1965 Cluster
23	FIGURE 20	1966 Cluster
24	FIGURE 21	2 Speed Wiper
25	FIGURE 22	Single Speed Wiper
26	FIGURE 23	Hazard Switch

27	FIGURE 24	2 Speed Blower
28	FIGURE 25	3 Speed Blower
29	FIGURE 26	Typical Fan Relay Activation
29	FIGURE 27	Thermostatic Switch Activation
30	FIGURE 28	Headlight Switch Pin Out
31	FIGURE 29	12V Relay Activation
31	FIGURE 30	Ground Relay Activation
33	FIGURE 31	Tail Section
33	FIGURE 32	Testing the System
34	FIGURE 33	Fuse Requirements

INTRODUCTION

You have purchased what we at Painless Performance Products believe to be the most up-to-date and easiest-to-install automotive wire harness on the market. It is designed for easy installation, even if you have little electrical experience.

The proper fuses have been pre-installed in the fuse block. In addition, all wires are color-coded. This will help you identify the different circuits during installation and later on if additions to the overall system are necessary. For fuse specifications and wire color designations, see the **Wire Index**.

The Painless wire harness is designed to be used in 1965 & 1966 Ford Mustangs. All wire is 600 volt, 125°C, TXL. Standard automotive wire is GPT, 300 volt, 80°C, with PVC insulation.

This complete automobile wiring system has been designed with four major groups incorporated into it:

ENGINE: Starter solenoid and battery feed, generator and alternator wire, water temperature, oil pressure, coil, electronic ignition, heater blower motor, choke, idle solenoid, and air conditioning.

HEADLIGHT GROUP: Includes high beam, low beam, park, right turn, left turn, electric fan, horns, and windshield washer motor.

DASH GROUP: Includes wires to connect gauges, indicator lights, windshield wiper motor and switches to their proper sources.

REAR LIGHT GROUP: Includes tail lights, rear courtesy lights, left and right turn signals, brake lights, reverse lights, and fuel sender.

Installation requires four (4) basic steps:

1. Mount the fuse block
2. Route the wires
3. Cut off the excess wire
4. Terminate the wires

CONTENTS OF THE PAINLESS WIRE HARNESS KIT

Refer to the photo below to take inventory. See that you have everything you're supposed to have in this kit. If anything is missing contact the dealer where you obtained the kit, or Painless Performance at (800) 423-9696. The Painless Wire Harness Kit should contain the following items:

- The Main Wire Harness, with the Fuse Block wired in and fuses installed, Headlight Harness
- Pig Tails: Windshield Wiper, 2 Instrument Panel sub harnesses, Heater Switch,

- Bag Kit containing 3 types of Nylon Tie Wraps, 10 Instrument Panel Light Bulbs, Maxi Fuse, Grommets, 2 Fire Wall Pass-through Plates, and a Fuse Identification Label.
- Parts Box containing Terminals, Splices, Spare Fuses etc.



Figure 1 The Painless Wire Harness Kit

TOOLS NEEDED

In addition to your regular tools, you will need, at least, the following tools:

- Crimping Tool *Note: Use a quality tool to avoid over-crimping.*
- Wire Stripper
- Test Light or Volt Meter
- Electric Drill
- 1-1/4" Hole Saw or grinding/ cutoff tool
- Small (10 amp or less) Battery Charger

PRE-INSTALLATION AND GENERAL HARNESS ROUTING GUIDELINES

The installation of your wire harness mainly consists in two parts:

- The physical routing and securing of the wire harness, wires, and groups.
- The proper connection of the individual circuits.

These two major tasks are not separate steps, but are integrated together. That is, you will route some wires and make some connections, route more wire and make more connections. We cannot tell you how to physically route the harness in your vehicle, although much of this harness follows the factory routing. We do offer some general guidelines and routing practices

starting. To help you begin thinking through the installation of your wire harness, familiarize yourself with the harness by locating each of the harness sections in the following list. Whenever a particular harness section is referred to in these instructions it is shown "all caps": ENGINE SECTION.

A/C-ELECTRIC FAN SWITCH SECTION	HAZARD SWITCH SECTION
ACCESSORY SECTION	IGNITION SWITCH SECTION
ENGINE SECTION	INSTRUMENT PANEL SECTION A
TURN SWITCH SECTION	INSTRUMENT PANEL SECTION B
HEADLIGHT SECTION A	RADIO/TACHOMETER SECTION
HEADLIGHT SECTION B	TAIL SECTION
HEADLIGHT/WIPER SWITCH SECTION	

*Note: For complete information concerning the individual circuits and wires that make up the harness SECTIONS, see the **Wire Index***

The Painless Wire Harness is designed for the fuse block to be mounted near the factory fuse block location.

A good exercise is to lay out the wire harness on the floor beside your Mustang and identify all the SECTIONS. You will want to route the harness through and around open areas. Inside edges provide protection from hazards and also provide places for tie wraps, clips and other support.

- Route the harness away from sharp edges, exhaust pipes, hood, trunk and door hinges.
- Plan where harness supports will be located. Allow enough slack at places where movement could occur (body to frame, frame to engine, etc.). Use a support every 12 inches unless the harness routes under the floor carpet.
- At wire ends don't depend on the terminals to support the harness. The weight of the harness could cause terminals to disconnect or copper wire strands to break.
- The wires should be bundled into groups. Use nylon ties, poly split loom, or tape.

HARNES GENERAL INSTALLATION INSTRUCTIONS

Rough Installation

CAUTION: DISCONNECT THE POWER FROM YOUR VEHICLE BY REMOVING THE NEGATIVE (BLACK) BATTERY CABLE FROM THE BATTERY. Make no wire connections or permanent mounting of any kind at this time!

- Mount the fuse block base with the self tapping screws provided. The screws simply need to be drilled through the bottom of the fuse block base and into the sheet metal **See Figure 2**
- Position the fuse block in its mounting area with the wires exiting from the top of the fuse block, and push to snap it into place. **See Figure 3**
- Enlarge the existing firewall opening at the driver's fender to 1- 1/4". Then route the 2 White HEADLIGHT SECTION B harness connectors through the 1-3/4" X 3 1/2" supplied pass through plate and grommet. Follow the same procedure for the ENGINE SECTION using the 3-1/2" X 3-1/2" supplied pass through plate and grommet. **See Figure 4**



Figure 2 Fuse Block Base Mounting



Figure 3 Fuse Block Position



Figure 4 Pass Through Plates and Grommets

- Route HEADLIGHT SECTION B wires through the opening and position the harness groups in the area near the left kick panel.
- Route dash group (TURN SWITCH SECTION, HEADLIGHT/WIPER SWITCH SECTION, INSTRUMENT PANEL SECTION A, RADIO/TACHOMETER SECTION, HAZARD SWITCH SECTION, IGNITION SWITCH SECTION, A/C- ELECTRIC FAN SWITCH SECTION, and ENGINE SECTION) upward to rear of dash and temporarily tie in place.
- Route the TAIL SECTION, through the kick panel, into the door sill channel on the driver's side of the car.

Harness Attachment

Note: Harness routing and shaping is and should be a time-consuming task. Taking your time will enhance the beauty of your installation. Please be patient and TAKE YOUR TIME!

- Mold harness groups to the contour of floor pan, firewall, fender panels, and any other area where wires or harness groups are routed. Remember to route the harness away from sharp edges, exhaust pipes, hood, trunk and door hinges.
- Attach harness groups to your automobile with clips or ties starting at the fuse block and working toward the rubber grommet for the front groups and along the floor pan for the rear group. The dash wires should be routed out of the way of any under-dash obstacles, such as cowl vent, air conditioning, radio, etc.

Note: Do not tighten tie wraps and mounting devices at this time. Make all harness attachments LOOSELY.

- When used every 1-1/2" or so on the visible areas of the harness, the plastic wire ties make a very attractive assembly. Painless PowerBraid is ideal for wires running in visible areas. A tie installed in other areas every 6" or so will hold the wires in place nicely. Remember to take your time!

Grounding the Automobile

A perfectly and beautifully wired automobile will nevertheless have bugs and problems if everything is not properly grounded. Do not go to the careful effort of installing a quality wire harness only to neglect proper grounding.

Note: The Painless Wire Harness Kit includes no ground wire except the black wire from the two headlamp connectors, a instrument panel ground, and a ground wire for the accessory relay. You must supply ground wire (14-16 gauge) for all other circuits.

- Connect a Ground Strap or Cable (even a 10-gauge wire is too small) from the Negative Battery terminal to the automobile chassis (frame).
- Connect a Ground Strap from the Engine to the chassis. **DO NOT RELY UPON THE MOTOR MOUNTS TO MAKE THIS CONNECTION.**
- Connect a Ground Strap from the Engine to the Body.

Terminal Installation and Making Connections

*Note: In the following steps you will be making the circuit connections. Before you start, you should carefully read **Sections 7.0**, as appropriate, and continually refer to **Section 8.0**, **DOUBLE-CHECKING** your routing and length calculations before cutting any wires and making connections. Give special attention to Turn Signal and Ignition Switch connections. These can be somewhat confusing.*

- Have all needed tools and connectors handy.
- Select the correct size terminal for the wire and stud application.
- Determine the correct wire length and cut the wire. Remember to allow enough slack in the harness and wires at places where movement could possibly occur, such as automobile body to frame, frame to engine, etc. **Double-check your calculations.**
- Strip insulation away from wire. Strip only enough necessary for the type of terminal lug you are using.

Note: In the following step, make sure that the terminal is crimped with the proper die in the crimping tool. An improper crimp will NOT make a good connection.

- Crimp the terminal onto the wire.

CAUTION: DO NOT OVER-CRIMP!

- Connecting the harness throughout the groups is a redundant process. Make sure that each wire is **FIRST** properly routed and **THEN** attach. **DO NOT ATTACH FIRST THEN ROUTE AFTERWARD.**
- When all wires are attached, tighten the mounts and ties to secure harness permanently.

Re-using Factory Connectors

Where ever possible, connectors have been pre-installed on the Painless harness. However, some connectors used on the early Mustangs are no longer produced. Connectors are not available in the aftermarket for the following components: Wiper Switch, Ignition Switch, and Headlight Switch.

Insulated terminals have been provided pre-installed on the Painless harness for all of the dash mounted switches. These terminals will allow connections to be made to these switches without the use of a connector. Some installers may prefer to re-use the factory connector, instead of using these push on style terminals. Factory style terminals have been supplied to replace the insulated terminals pre-installed on the Painless harness. It is up to the installer to remove the pre-installed insulated terminal, and reinstall the correct terminal in order to re-pin the factory connect onto the Painless Harness if they desire.

Removal of the Connectors from the Factory Harness

The factory terminals in the connectors have a locking tang that keeps them from being pulled out from the connector. This tang can be seen in the photo to the right. In order to remove the terminal from the connector, the tang must be flattened down and the terminal pulled from the connector. It is a good idea to write down the wire color going to each location before any wire is removed from the connector. Pin outs are available in this manual, however your own notes may prove to be more valuable to you.

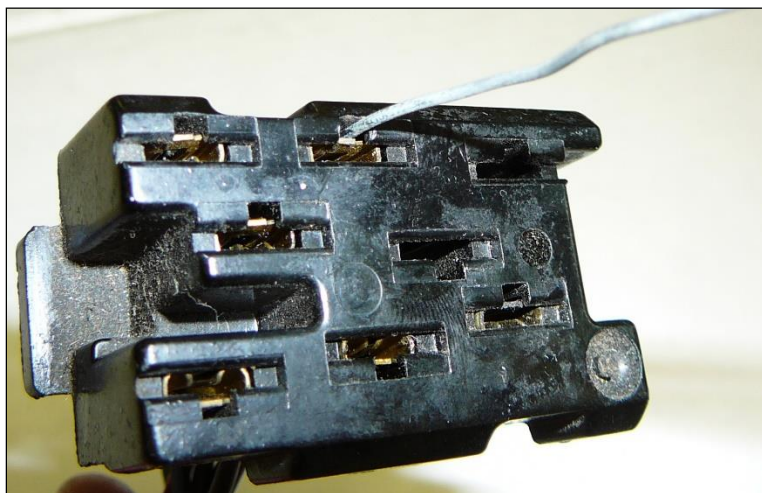

- Looking at the switch side of the connector you will notice little openings above or below the terminals. This little opening gives you access to the locking tang on the terminal.
 - Insert a small pick, a paper clip, or a thin piece of stiff wire into this opening. Apply a slight amount of pressure to make sure you are as far into the connector as you can go.
 - As the wire or pick is being pushed into the opening, pull the wire from the opposite side of the connector to remove the wire from its location.
- This procedure can be applied to the removal of the factory connectors for the Wiper Switch, Ignition switch, and Headlight Switch.

Painless Performance Products offers part **#70900** for crimping non insulated "factory" style terminals, these crimpers can be seen in the photo on the next page

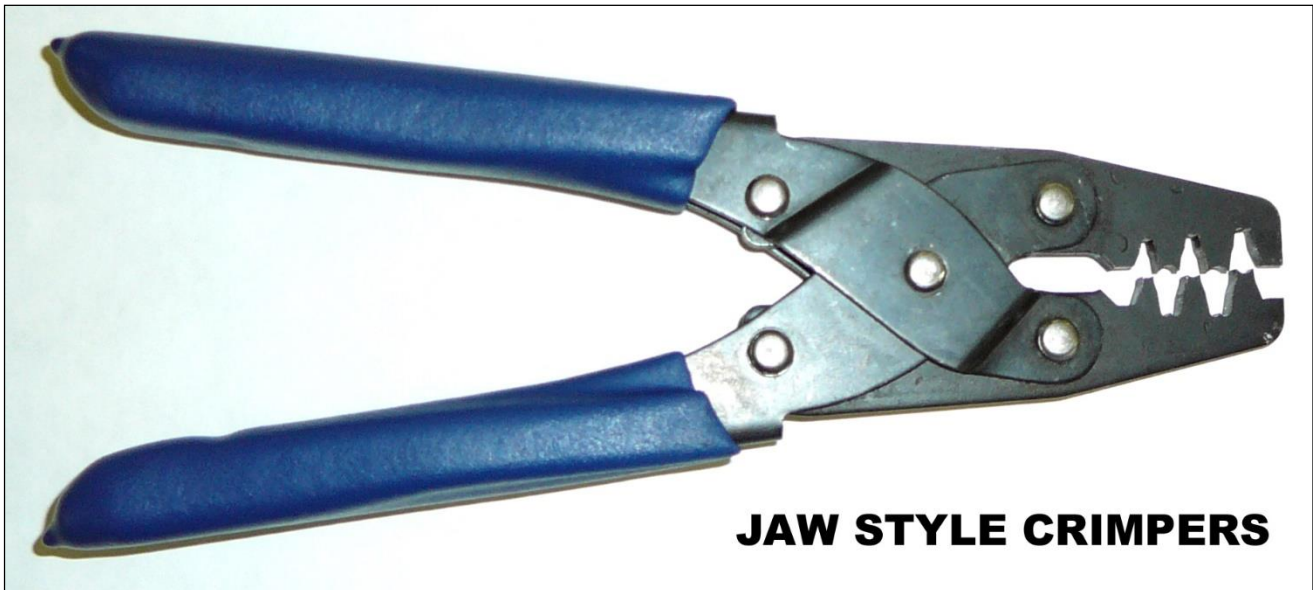

SPECIFIC CIRCUIT CONNECTIONS

Headlight Section B Wiring

- Connect the wires in HEADLIGHT SECTION B according to **Figure 8**. All Headlight wires, Turn signal/park lamp connections, and both Horn wires are terminated and have the correct connectors already installed, locate the left and right side of both and make the connections. Ground the (blk) wires from the headlight connector to the chassis.
- Connect wire #968 (blk/wht) from the Wiper Switch to the Windshield Washer Pump. This wire will provide power from the wiper switch to the washer motor.
- If using an externally regulated alternator, the same style charging system used from the factory, connect the pre-installed regulator connector onto the regulator found on the driver side core support.
- Connect the 14-gauge wire #981 (blk/red) with the pre-installed ring terminal to a mounting bolt of the regulator. This will provide a clean ground to the alternator.
- Connect wire #901 (gry/wht) to the Electric Cooling Fan Relay (**Painless Performance Part #30101, Fan-Thom Electric Fan Relay Kit**) *This wire is an activation wire for the relay, **NOT A POWER FEED TO THE FAN MOTOR.*** Refer to **Figures 26 & 27**. If a mechanical fan is being used, this wire will not be needed.

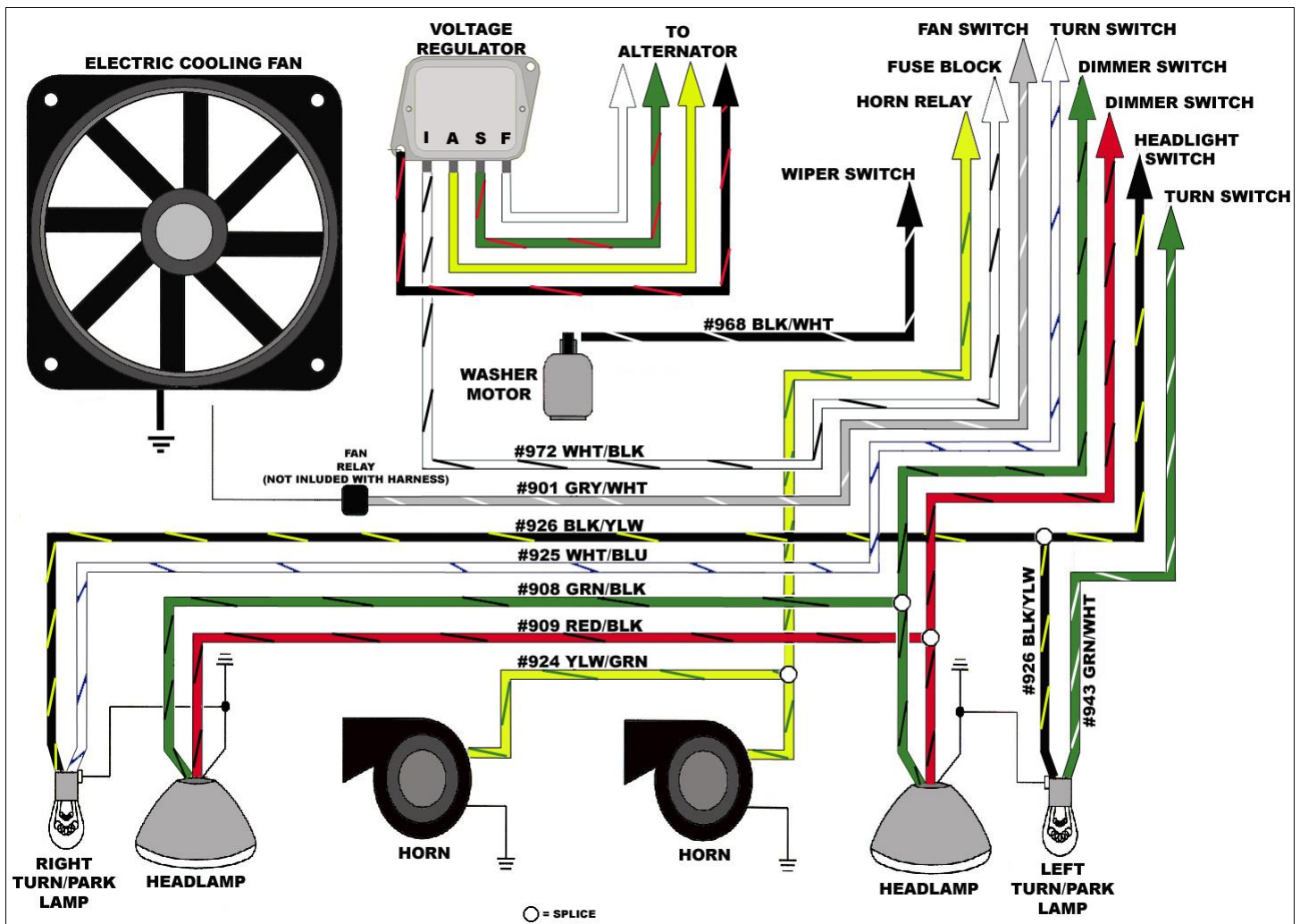

Figure 8 Headlight Section B Wiring

With the alternator wires of Headlight Section B routed over to the Alternator, connect them as described below and as shown in **Figure 9**.

- Connect the 14-gauge wire #915 (grn/red) from the Voltage Regulator "S" terminal to the Alternator Stator "S" terminal.
- Connect a 14-gauge wire #970 (wht) from the Voltage Regulator "F" terminal to the Alternator Field "F" terminal.
- Connect the 14-gauge wire #981 (blk/red) to the Alternator Ground lug.
- Connect ENGINE SECTION wire #971(blk/ylw) from the fuse block to the Alternator Output lug "Bat". The 14-gauge wire #913 (ylw) from the Voltage Regulator "A" terminal will also connect to the output lug.

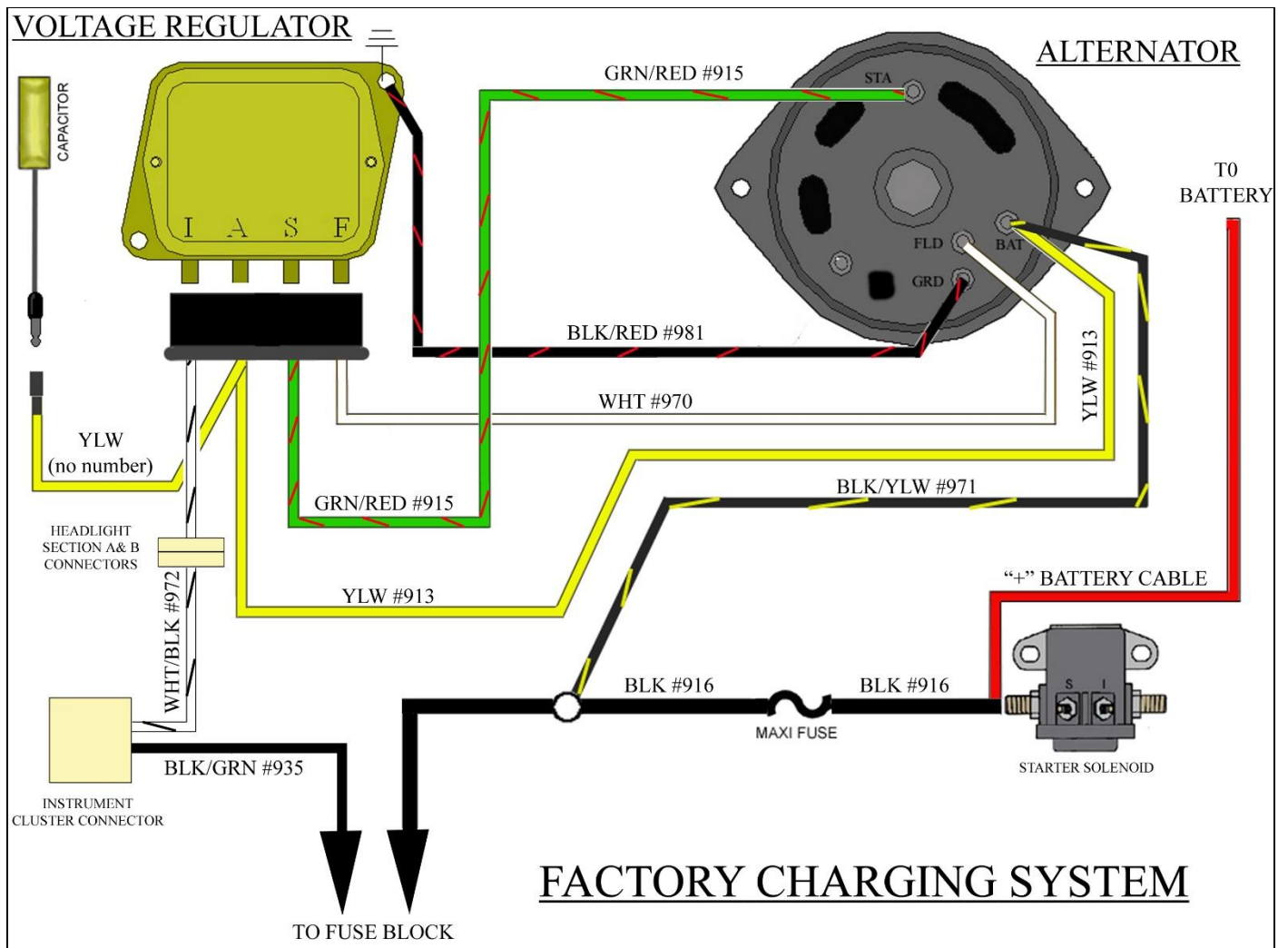

Figure 9 Ford Alternator

Note: Your Alternator may not appear exactly as represented in **Figure 9**. The circuits are wired the same way, though.

Note: If you experience engine run on after turning off the ignition switch, a diode (Radio Shack Part #276-1661) must be installed to the Voltage Regulator "exciter" wire. Splice the diode into wire #972 (wht/blk) near the voltage regulator, **the stripe on the diode should face towards the regulator**. A faulty voltage regulator can also cause this problem.

ENGINE WIRING

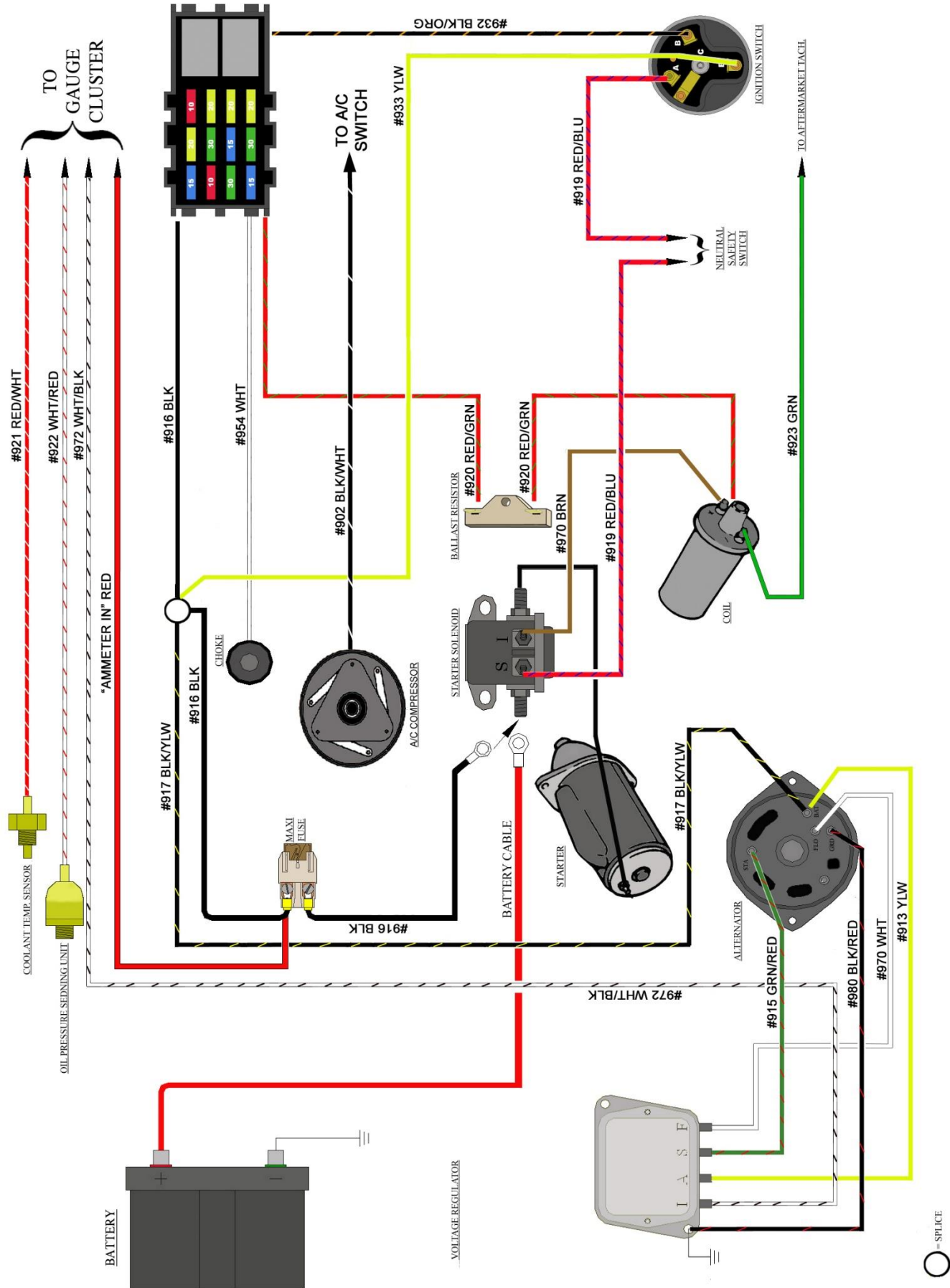

Figure 10 Engine Wiring

Engine Section



Maxi Fuse

This large fuse isolates the battery from the Alternator and the harness. This serves as a fuse to protect the entire harness. **DO NOT OMIT IT.**

This fuse, and everything required for installation, can be found in the parts kit (seen in the photo to the left). These parts are:

- A MAXI FUSE Base & Cover
- a self-tapping mounting screw
- 70 AMP MAXI FUSE

To install:

- Find a suitable location for the Maxi Fuse base. It can be mounted anywhere in the engine compartment, preferably near the battery. Make sure you allow enough room to get the cover off and on, avoid mounting it near excessive heat. Also take into consideration the length of wires you need for #916, see below.
- Using the mounting screw and the hole found on the top of the base, install the MAXI FUSE Base
- Install the 70 amp Maxi fuse and cover at this time.
- In the ENGINE SECTION, locate the 3 wires labeled **MAXI FUSE**. Using a supplied ring terminal, connect #916 "From the Starter Solenoid..." wire to one side of the Maxi Fuse.
- Connect the other #916 "...to the Fuse Block" wire to the other side of the Maxi Fuse. The red wire will only be used by those using an Ammeter. It will double with the #916 Fuse block wire, see **Figure 9**.

Ford Ignition & Start/Run System

- Connect wire #916 (blk)– with Maxi Fuse installed – to the Starter Solenoid Battery terminal. This is the same lug that the large cable from the battery "+" will be connected. This is the main power feed for the harness.
- Connect ENGINE SECTION wire #919 (red/blu) to the Starter Solenoid Start "S" terminal.



A ballast resistor, supplied with the harness and seen in the photo to the left, will be needed if you do not have a newer internally resisted coil. **Neglecting to use the supplied ceramic ballast resistor on a coil that requires a resisted 12v supply, will cause the coil to quickly overheat leading to complete coil failure.**

- If you are using the Ballast Resistor, mount it away from other wiring or hoses. The Ballast Resistor gets very hot during operation. Connect ENGINE SECTION wire #920 (red/grn) to one end of the Ballast Resistor. Connect the other end of the Ballast Resistor to the Ignition Coil B+ terminal with 16-gauge wire (you will have enough wire left over to accomplish this).

- Connect a 16-gauge #970 (brn) wire from the Starter Solenoid Ignition "I" terminal to the coil side of the Ballast Resistor or directly to the coil + post. This wire serves as a ballast resistor BYPASS during engine starting. If you are not using a ballast resistor, this wire will not need to be connected to coil or starter solenoid and may be removed from the harness.
- Connect ENGINE SECTION wire #923 (grn) to the Ignition Coil NEGATIVE (-) terminal. This is the tachometer source. If you are not using an aftermarket tachometer, insulate and stow wire #923 (grn).

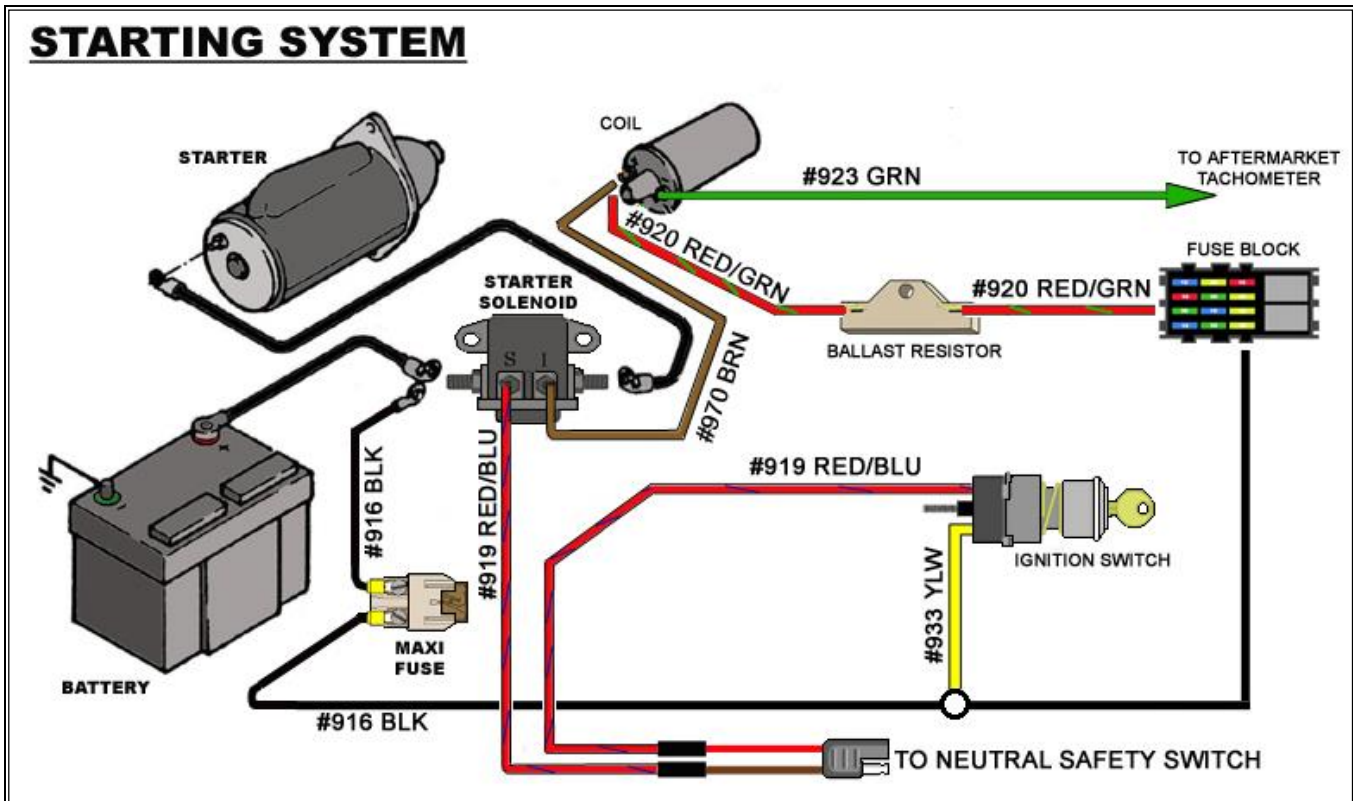

Figure 12 Ford Start/Run System

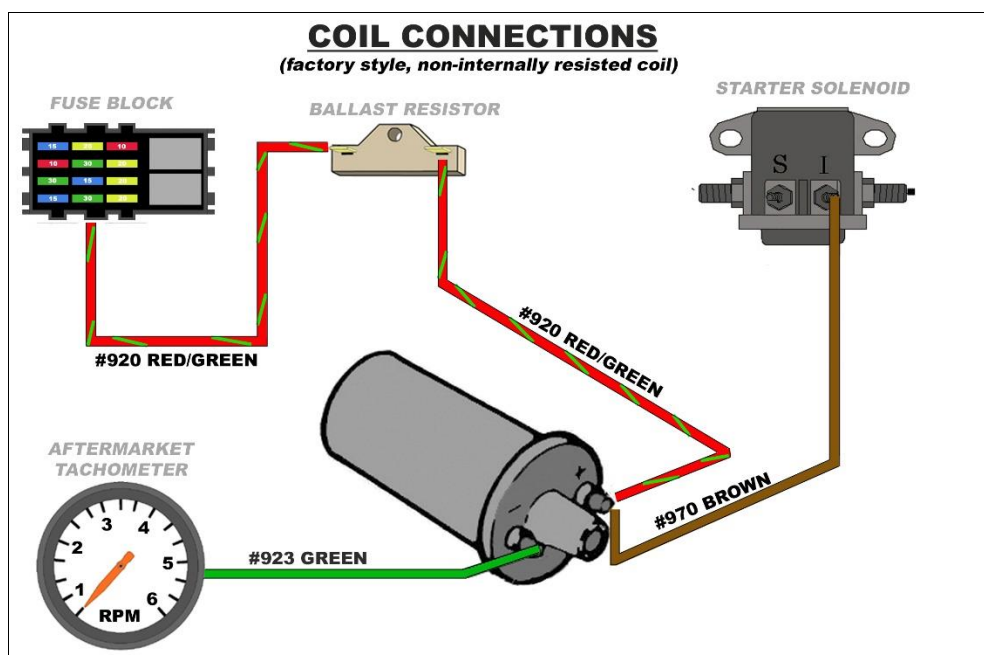

Figure 13 Factory Ignition System

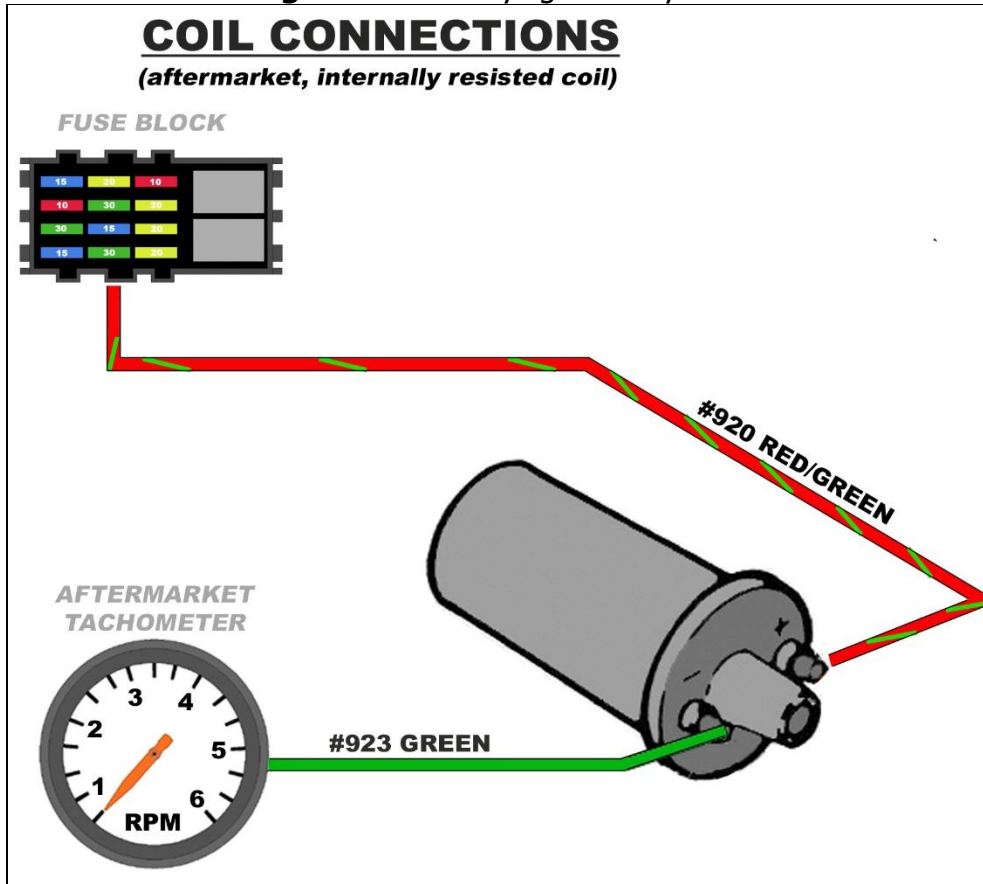

Figure 14 Internally Resisted Coil Connections

MSD IGNITION CONNECTIONS

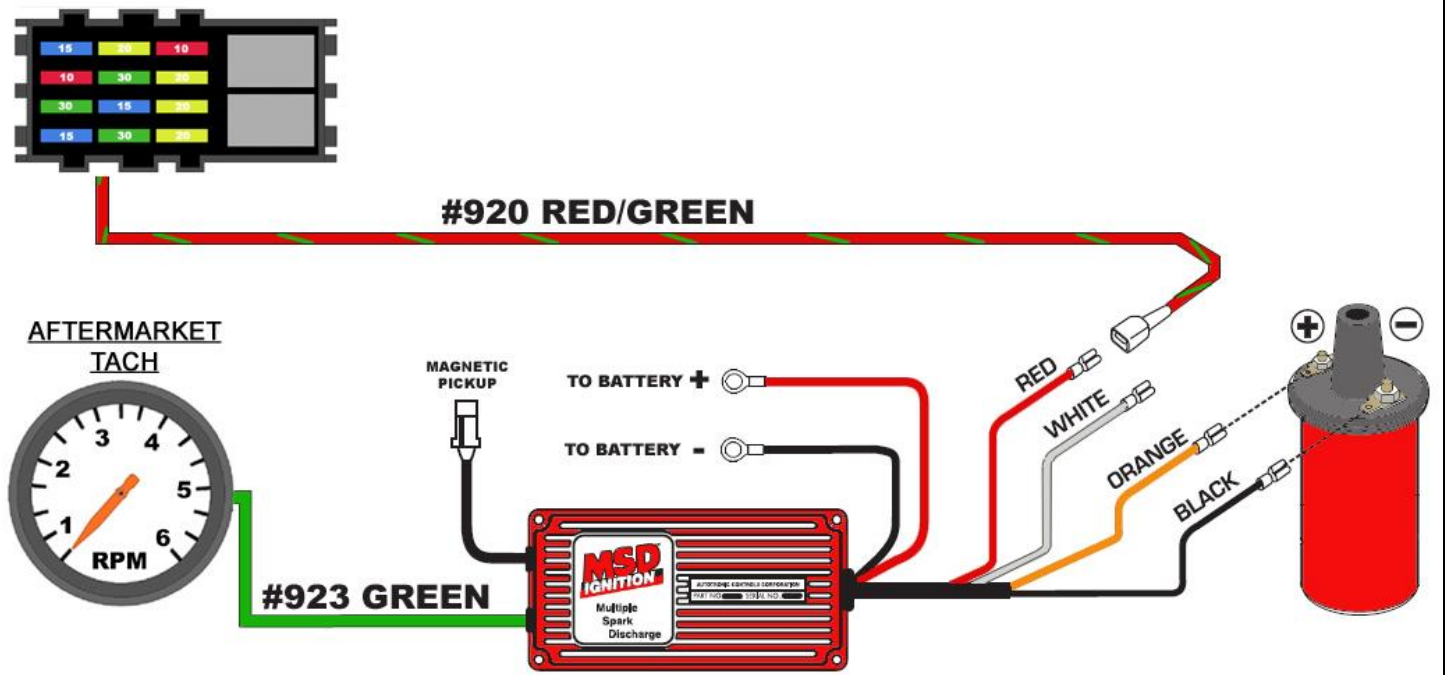

Figure 15 MSD Connections

Blower Motor Wiring

- Connect wire #904 (brn) in the ENGINE SECTION to the Brown (Black/Yellow on some models) wire on the Heater Blower Motor.
- Connect wire #903 (ylw) in the ENGINE SECTION to the Yellow (Red on some models) wire on the Heater Blower Motor.

Both wires can be seen in **Figures 24 & 25**.

Neutral Safety/Reverse Switch

Extra length has been given to these wires to accommodate those using aftermarket floor shifters that have Neutral Safety/ Reverse switches attached to their bases. Molded connectors are provided in the parts kit to allow connection to the factory Neutral Safety/Reverse Switch.

- Connect the two #919 (reb/blu) wires to the Neutral Safety Switch. These wires can connect to either side of the switch. The colors of the Painless harness should match your factory colors.
- Connect the #953 (blk/red) and #991 (blk/red) wires to the Reverse Switch. These wires can connect to either side of the switch. The colors of the Painless harness should match your factory colors.

Interior Wiring

Steering Column Wiring-Turn Signal Connections

- Connect the 6-way and the 2-way connectors labeled TURN SWITCH SECTION to the factory steering column harness. These connectors will plug directly to the existing connectors and will take care of all the Turn Switch connections.

For those using an aftermarket steering column that uses GM connectors, use the following set of directions and diagram to correctly pin out your column connector (not supplied with this kit)

- Cut the pre-installed 6 pin and 2 pin connectors from the Painless harness.
- Using a splice found in the parts kit, connect the yellow wire and blk/red wire together. This will supply the Horn relay found on the fuse block with a constant switched 12v power source. Ford Columns passed power through the horn button, while Gm columns pass chassis ground through the horn button.
- Locate the #969 blk/wht wire near the Instrument Panel section with the pre-installed red ring terminal. This blk/wht wire will need to have the ring terminal removed then routed and connected to pin G of the GM column connector. This wire provides a ground source to the relay. Instead of applying a constant ground, like done with a Ford Column, it will now carry the switched ground source from the horn button to the horn relay.
- Use **Figure 16** for the connection of the remaining wires from the Painless harness.

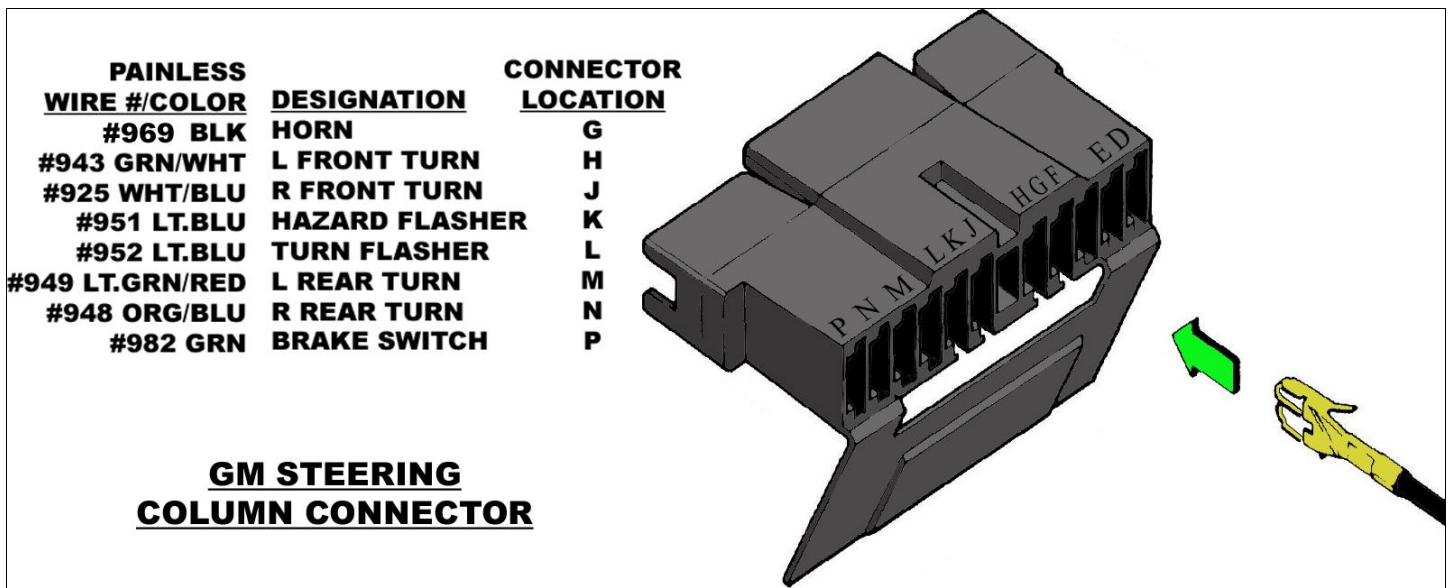
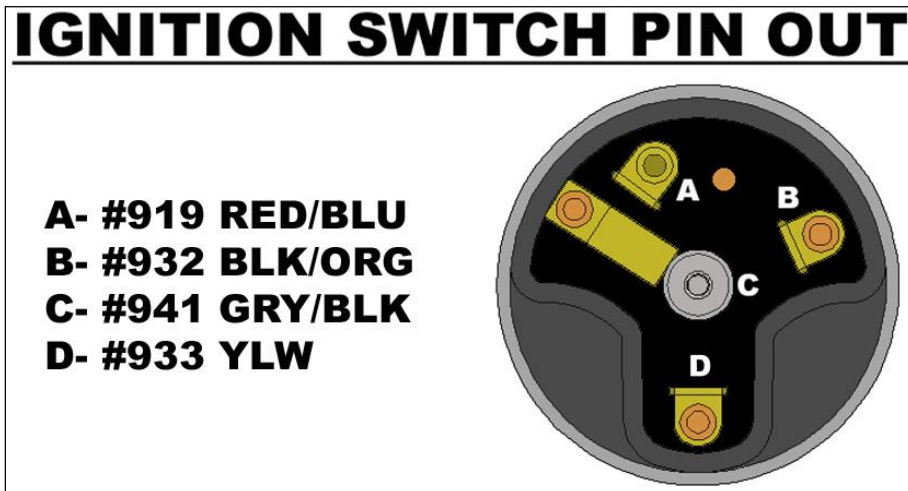

Figure 16 GM Steering Column Connector

Ignition Switch Connections



- Connect the wires of the IGNITION SWITCH SECTION according to **Figure 17**.
- Wire #919 (red/blu) is the Start signal
- Wire #932 (blk/org) is the output wire that provides the fuseblock with a switched 12v power source.
- Wire #941 (gry/blk) is a 12v accessory hot wire.
- Wire #933 is the power input to the Ignition Switch from the battery.

Figure 17 Ignition Switch

Connections

Interior Lighting

Interior Lights are switched through the door switches and the dash-mounted headlight switch, which is usually rotated counter-clockwise to turn on; these switches apply 12v to the Interior Lighting circuit.

The Glove Box and Courtesy Light bulbs are grounded through their housings and mounting points so make sure that they are clean and tight.

The specific courtesy lamp locations will have a label indicating its proper connection. These wires are blk/blu and will have a male terminal pre-installed and can be used for powering the courtesy and door lights.

Due to the different types of Interior Lighting options, you may not have all of the necessary wiring to accommodate your specific interior lighting package. Rear quarter panel light

wiring for both left and right sides as well as wiring for the Glove Box light is provided along with connection points for Center Console, and Door lights. If possible leave your existing interior light wiring intact. It will be necessary to reuse some of the original wiring or add new wiring were applicable. The Painless harness supplies the 12V feed (B+) to the circuit via wire #918 (lt.grn/ylw) and wire #945 (blk/blu).

This following set of directions will allow the Interior Lights to be turned on when either of the doors are opened.

- Connect wire #918 (lt.grn/ylw) and wire #945 (blk/blu) to the left door jamb switch
- The right door jamb switch is also connected using a separate pair of wires also printed #918 (lt.grn/ylw) and wire #945 (blk/blu).

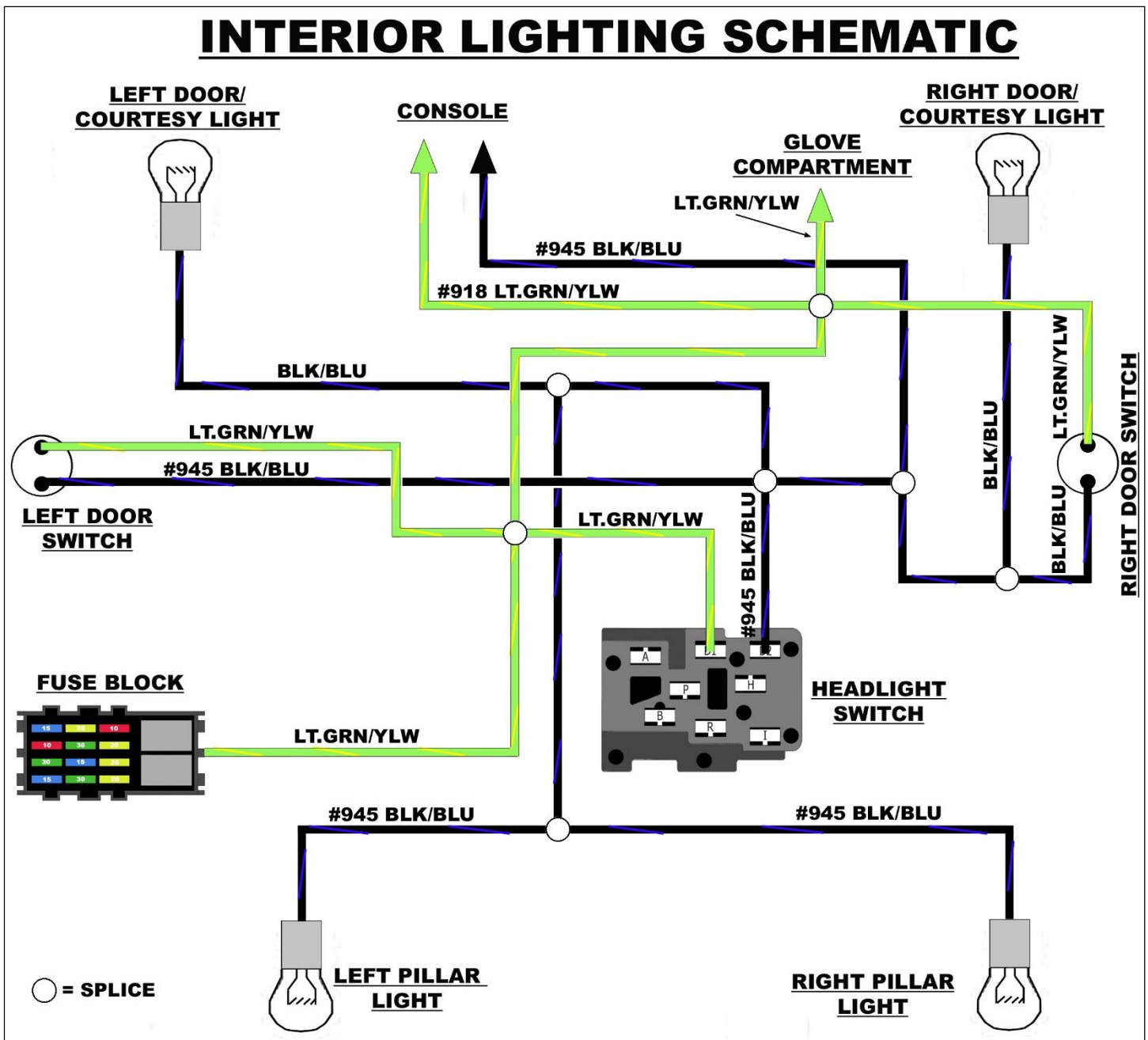

Figure 18 Interior Lighting Schematic

Brake Light Switch

- Route the brake switch wires #917 (lt.grn/red) and #982 (grn) in HEADLIGHT SECTION A, from the driver side kick panel, over the steering column, and behind the instrument panel opening to the brake switch located on the brake pedal.
- Install the brake switch wires, wires #917 (lt.grn/red) and #982 (grn), onto the brake switch. These two wires are interchangeable and can be installed on either side of the connector. These wires are terminated with push on terminals and install directly to the tabs on the Brake Switch.

Instrument Panel Wiring

The Painless harness kit contains 2 pigtail assemblies, "1965 Cluster" and "1966 Cluster". Each pigtail assembly will connect to the instrument panel connector found on the Painless harness and provide all of the proper connections pre-terminated according to which year cluster you are using.

- Connect the appropriate pigtail according to what year cluster your particular install is using. This pigtail will plug into the 10 pin "Instrument Panel" connector found on the Painless harness. If you are unsure of which gauge cluster your car currently has, photos of the clusters can be found on the next page.
- Connect dash power wire labeled CONSTANT VOLTAGE REGULATOR (lt.grn/red) with female terminal to the Constant Voltage Regulator on the "In" terminal. Connect the wire labeled CONSTANT VOLTAGE REGULATOR (blk/grn) wire with male terminal to the Constant Voltage Regulator on the "Out" terminal. Connect the remainder of the blk/grn wires to the "I" post on the Oil, Temperature and Fuel Gauges.
- Connect wire #922 (wht/red) to the "S" post of the Oil Pressure Gauge (1966 gauge only)
- Connect wire #921 (red/wht) to the "S" post of the Temperature Gauge
- Connect wire #939 (ylw) to the "S" post of the Fuel Gauge.
- 1966 Clusters have an Ammeter, locate the un-numbered red and yellow wires labeled "Ammeter". Connect the un-numbered red wire to the "IN" post and yellow wire to the "OUT" post as shown in **Figure 20**.
- After installing the bulbs (supplied) into the black lamp sockets, snap the lamp sockets into their correct locations.
- Wire #923 (grn) supplies the tachometer signal from the ignition coil; follow the instructions with your tachometer for proper installation. Power is provided by wire #934 (lt.grn/red). A ground can be taken from the (blk) wire labeled GROUND in INSTRUMENT PANEL SECTION B.

1965 CLUSTER

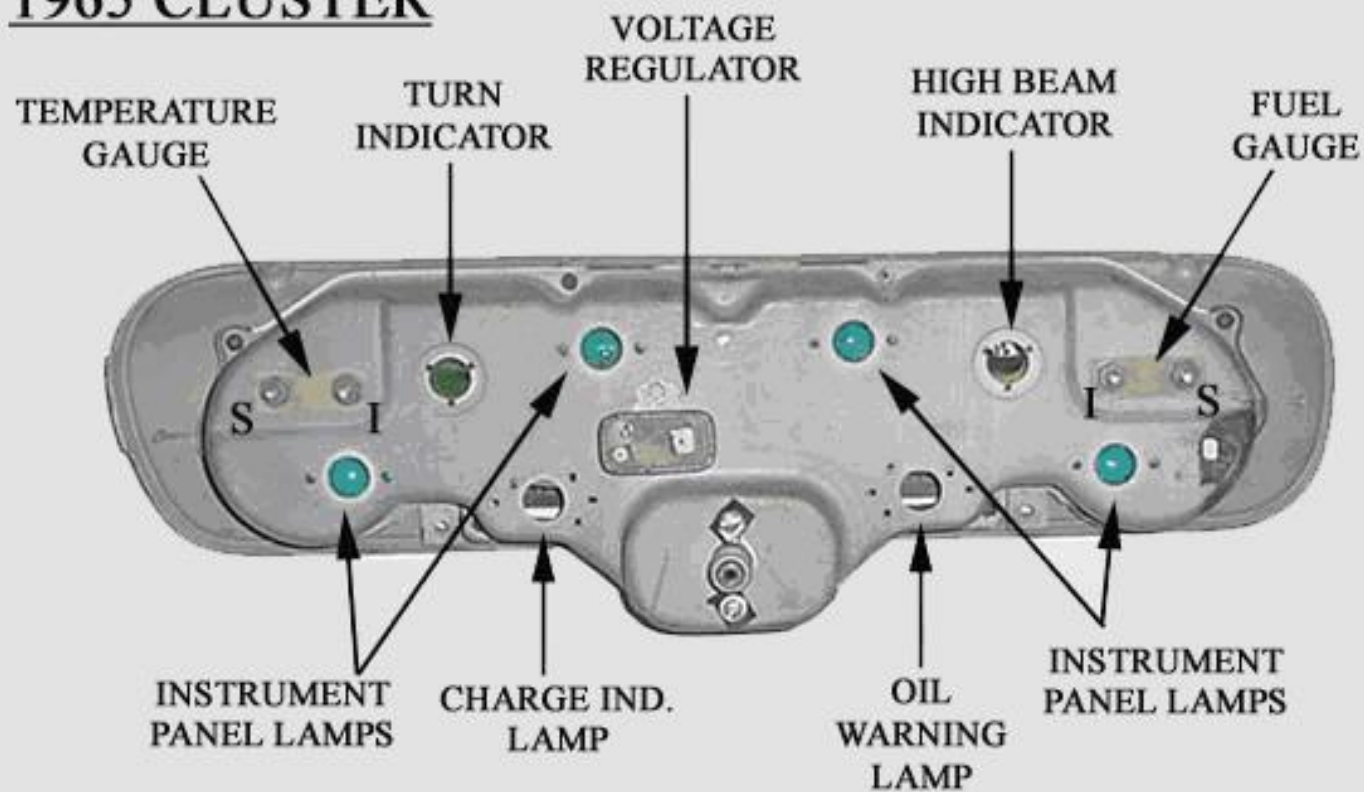

Figure 19 1965 Instrument Panel

1966 CLUSTER

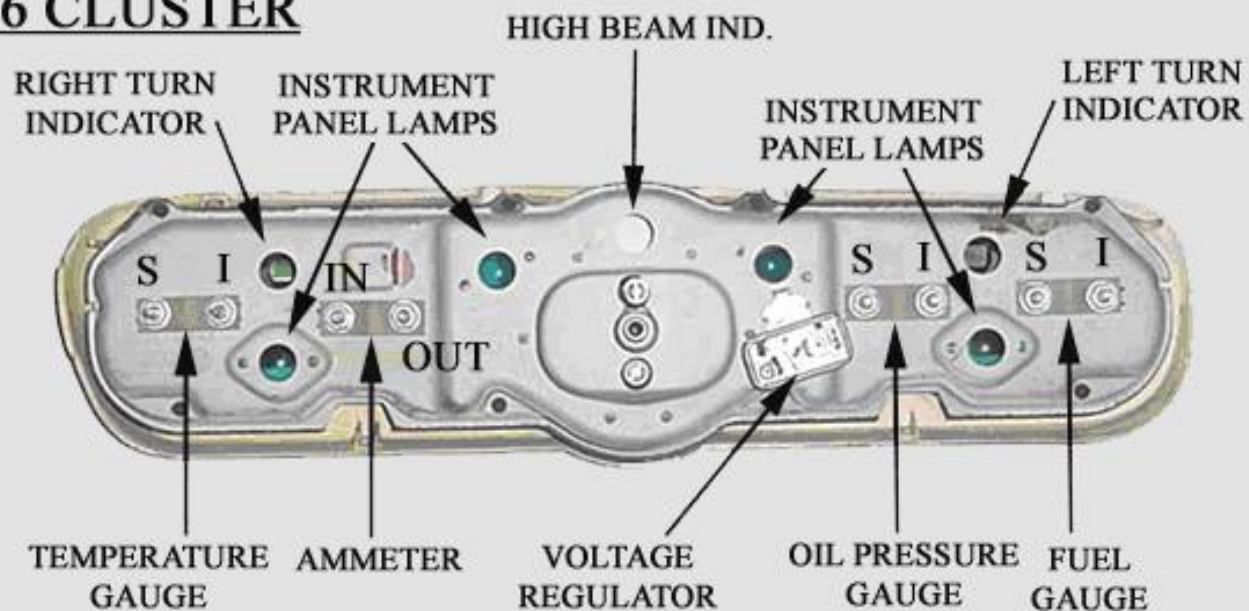

Figure 20 1966 instrument Panel

Wiper Switch Wiring (Single Speed and Two Speed)

Two Speed

- For Two Speed Wiper Systems, connect the wires of the Wiper switch as indicated in **Figure 21**. These connection will be made using the 2 wires, #905 (org/wht) & #968 (blk/wht), found on the main harness and the Wiper system sub harness included with the kit.
- The opposite ends of Wire numbers, #966 (wht), #993 (lt.blu), #967 (ylw) and #930 (lt.grn) have molded connectors pre-installed and will connect to the factory four way connector found on the Wiper Motor. These wires are color coded to match the original harness but due to inconsistent wire coloring check these circuits to be sure.
- Connect the two wires, #930 (lt.grn), with the female spade terminals to the two male power terminals on the side of the Wiper Motor. It does not matter which wire is connected to each tab.
- Connect the remaining blk wire with the ring terminal to a clean chassis ground. The opposite end of this wire will connect to the black ground wire found on the Wiper Motor.

TWO SPEED WIPER SYSTEM

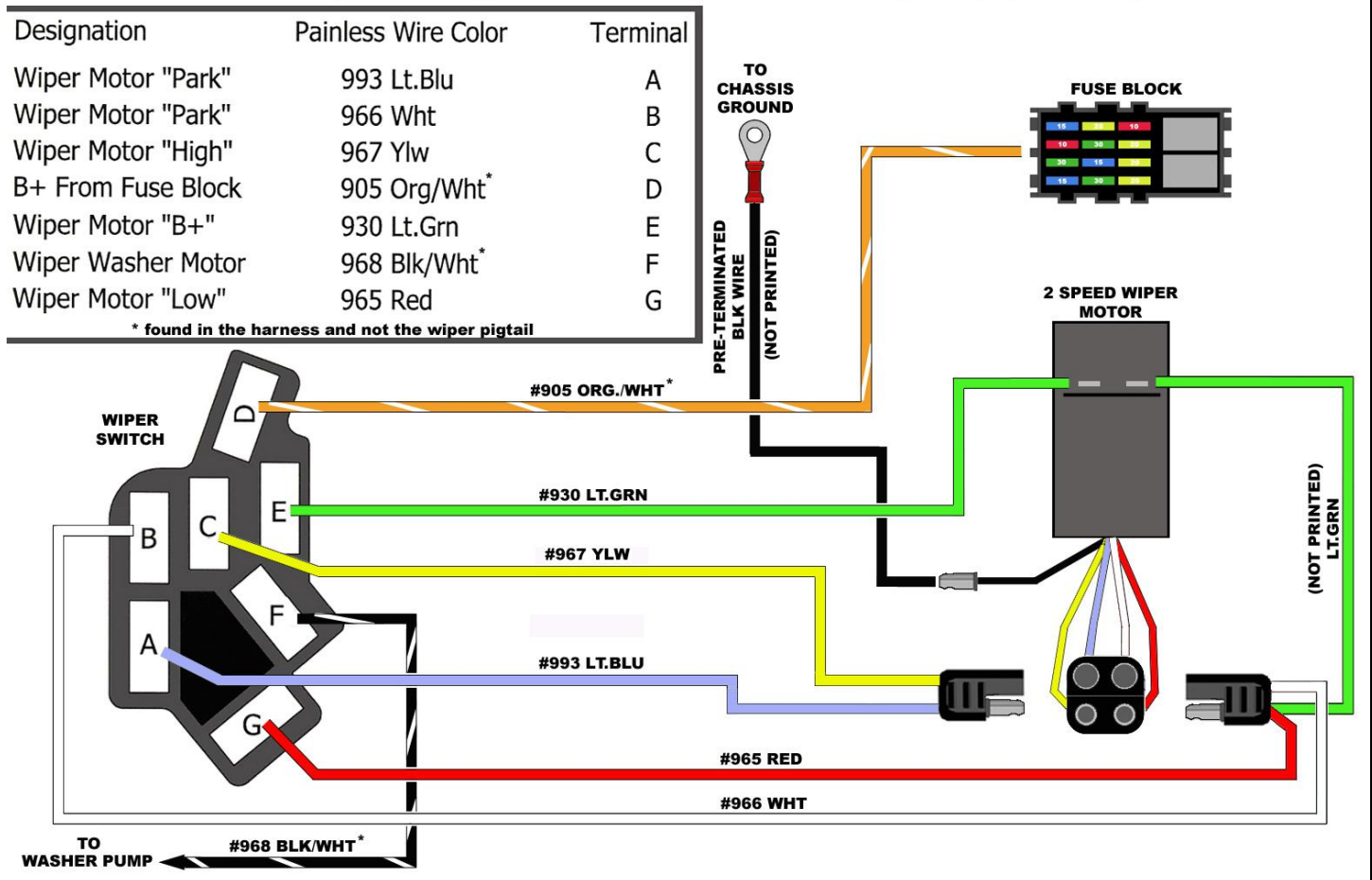

Figure 21 Two Speed Wiper Switch Connections (Wire Side View)

Single Speed

- Begin by cutting the pre-installed molded connectors from the Wiper System sub harness. These were pre-installed for those running a Two Speed Wiper system.
- Discard the #965 (red) and the un-printed Lt.grn wire that doubled with it. These wires are not needed. Wire #968 (blk/wht), found on the harness, will also not be used.
- Connect the wires of the WIPER SWITCH as indicated in **Figure 22**.
- Connect wire #966 (wht) from the Wiper Switch to the Wiper Motor "park" circuit.
- Connect wire #967 (ylw) from the Wiper Switch to the Wiper Motor "On" circuit.
- Connect wire #993 (lt.Blu) from the Wiper Switch to the Wiper Motor "Constant B+" Circuit.
- Connect the ring terminal with the black wire to a clean chassis ground.
- Double #930 (lt.grn) with the opposite end of the Black wire and connect them to the Ground wire coming from the Wiper Motor as shown in **Figure 22**.

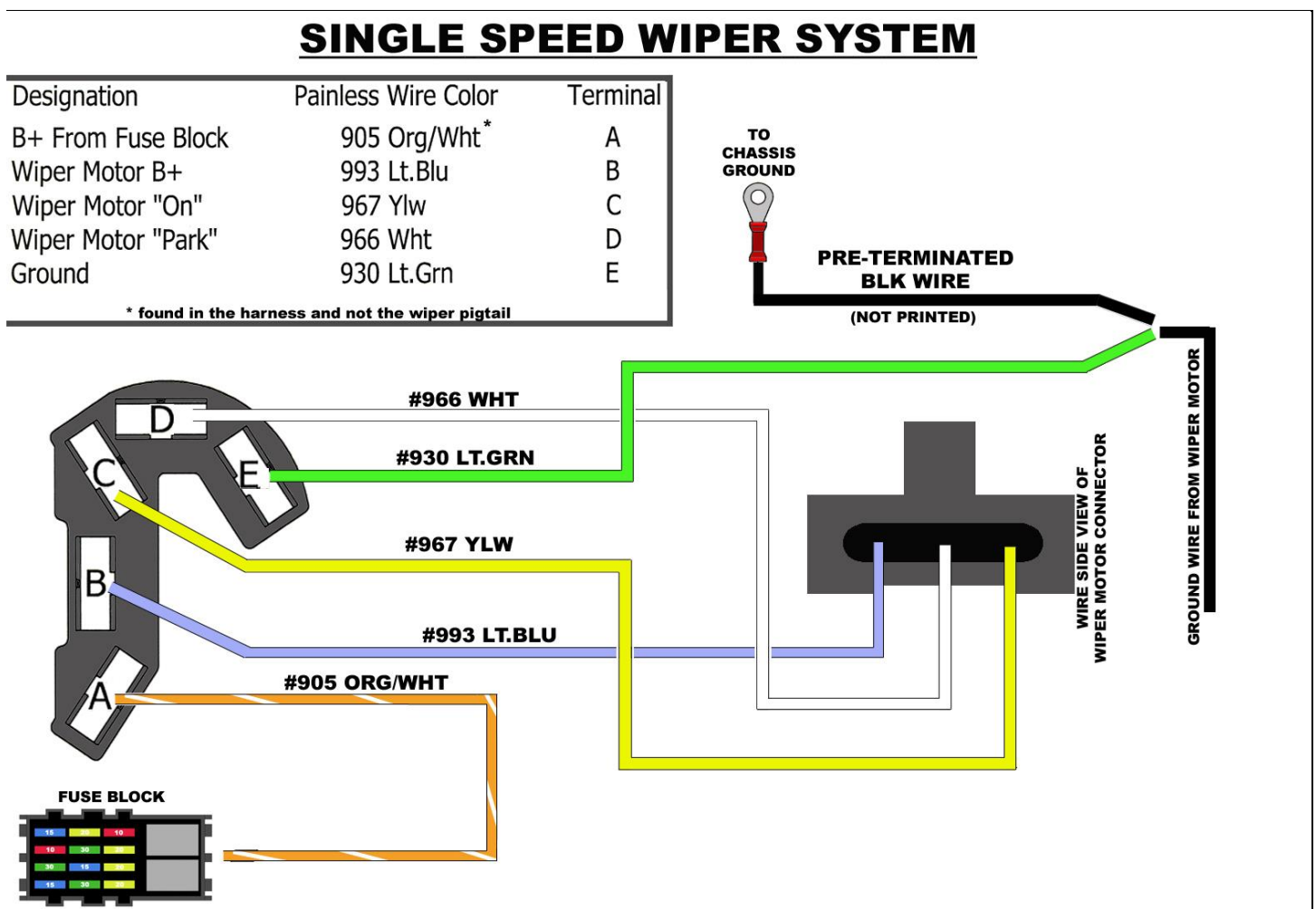

Figure 22 Single Speed Wiper Switch Connections (Wire Side View)

Hazard Switch Wiring

- Connect the wires of the HAZARD SWITCH SECTION as indicated in **Figure 23**. The terminals on the Hazard Switch are made to the switch, it may be necessary to splice into the original Hazard Switch Harness. The original wires can be removed using a soldering iron, making it possible to solder the new Painless Wires to the original terminals.

Designation	Painless Wire Color	Terminal	
Right Front Turn Lamp	925 Wht/Blu	A	
Brake Switch	982 Grn	B	
Left Front Turn Lamp	943 Grn/Wht	C	
Hazard Flasher	951 Lt.Blu	D	

Figure 23 Hazard Switch Wiring

Heater-A/C Switch Wiring

Note: 1965 & 1966 Mustangs had two types of Blower Motor Switches, a two speed switch and a three speed switch. Decide which type of switch you have and connect the switch according to the one of the following two procedures.

2 Speed

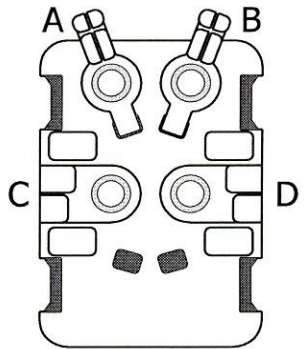
- Locate the 2 #904 (brn) wires and the #900 and un-printed blk/wht wires with the push in terminals. These 2 wires can be found near the "Ignition Switch" and the "A/C, Electric Fan Switch" breakouts.
- For 2 speed switches, connect #904 (brn) to #904 (brn). The 2 blk/wht wires will also connect to each other. This will now send power from the fuse block through the blk/wht wire, to #900 (blk/wht), to the heater switch.
- Connect wire #903 (ylw) to the blower motor switch. There are 3 positions on the 2 speed blower switch. If looking at the wire side of the switch, the #903 (ylw) will connect to the left side.
- Connect wire #900 (blk/wht) to the center position of the switch.
- Connect #904 (brn) to the right side of the switch.

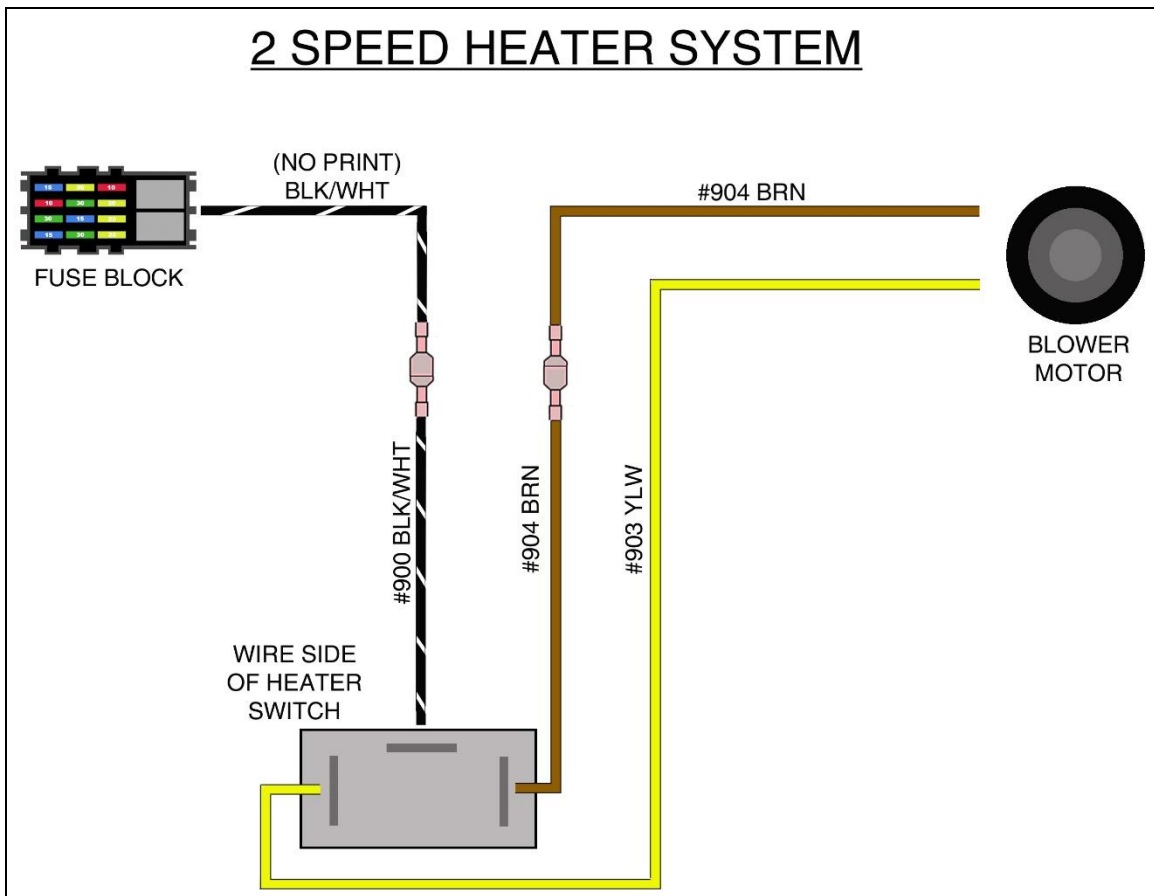

Figure 24 2 Speed blower Schematic

3 Speed

- Locate the #904 (brn) wire and the un-printed blk/wht wire with the push in terminals. These 2 wires can be found near the "Ignition Switch" and the "A/C, Electric Fan Switch" breakouts.
- For 3 speed switches, connect #904 (brn) to the un-printed blk/wht wire. This will now send power from the Fuse block through the blk/white wire, to the #904 (brn) wire, out to the blower motor.
- For three speed switches wire #903 (ylw) is connected to the single tab on the Heater Blower Motor Resistor.
- Plug the three way connector on the HEATER SWITCH PIG TAIL on to the Blower Motor Resistor and route the other end of the pig tail to the Heater Switch. The wires at the Blower Motor Switch are soldered onto the terminals, it may be necessary to splice onto these wires. These wires can be removed with a soldering iron allowing the new Painless wires to be soldered directly to the Heater Switch terminals. The wire colors at the Blower Motor Switch may vary so reference the factory wiring from the switch to the resistor, if possible, to identify the correct wire locations.
- Connect wire #992 (blk/grn) to the Blower Motor Switch "LOW" wire or terminal.
- Connect wire #994 (lt.blu) to the Blower Motor Switch "MED" wire or terminal.
- Connect wire #910 (wht/blk) to the Blower Motor Switch "HIGH" wire or terminal.
- Wire #900 (blk/wht) and #904 (brn) that are grouped with #903 (ylw) will not be used with the 3 speed

3 SPEED BLOWER

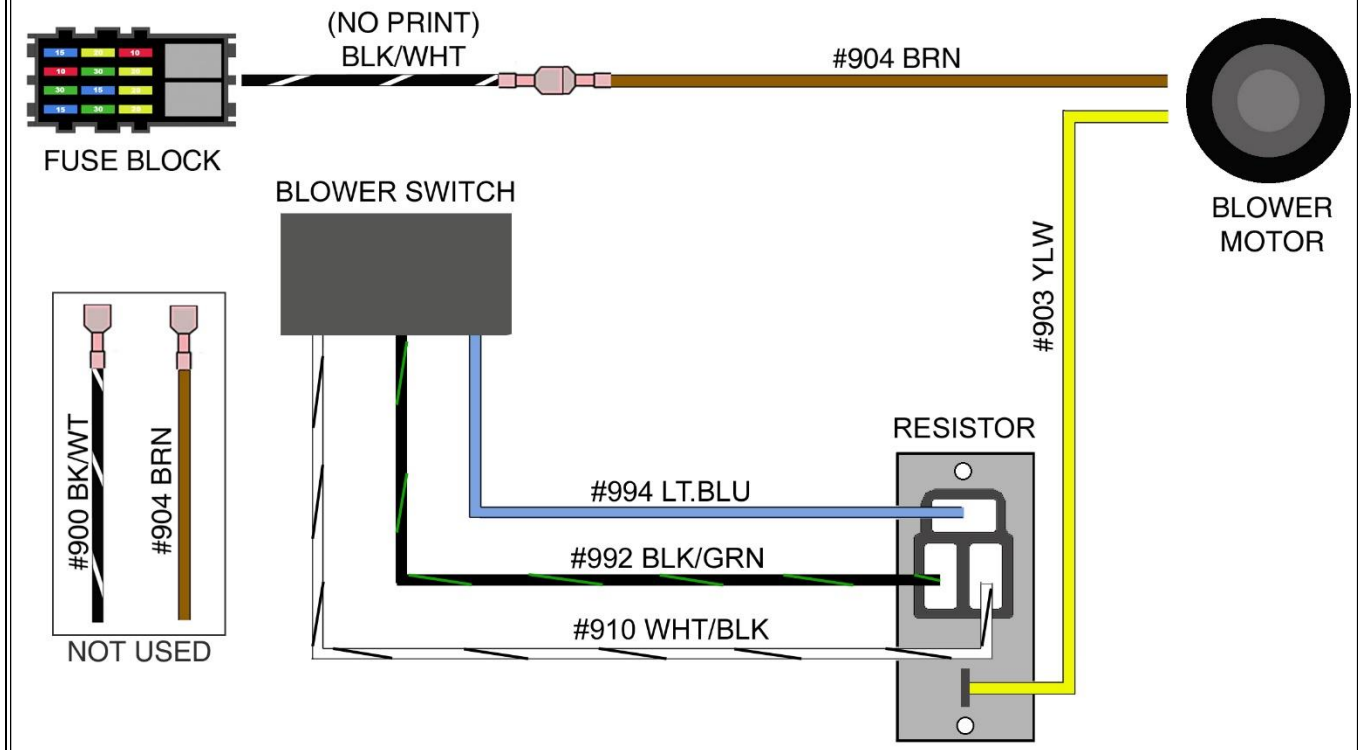

Figure 25 3 Speed blower Schematic

Provisions have been included in this harness for Mustangs with Air Conditioning. Locate the two blk/wht wires and the two gry/wht wires labeled together as A/C-ELECTRIC FAN.

A/C Switch

- Connect the blk/wht wire that is NOT printed to the B+ side of the A/C Switch.
- Connect wire #902 (blk/wht) to the remaining A/C Switch wire, this wire goes out to A/C Compressor.

Cooling Fan Switch

The two gry/wht wires found in the group of wires labeled "A/C, Electric Fan Switch" are for an electric cooling fan switch. If using an electric cooling fan, locate a suitable mounting point for the switch. *Enough wire is provided for mounting the cooling fan switch in several locations around the instrument panel.* If an Electric Cooling Fan is not being used, insulate the end of the unused #906 wire to prevent it from shorting to ground. This wire is a switched 12volt wire.

- Connect wire #906 (gry/wht) from the fuse block to one side of the Electric Cooling Fan Switch, this wire supplies power to the switch.
- Connect wire #901 (gry/wht) to the other side of the Electric Cooling Fan Switch.

The Cooling Fan Switch wires can also be spliced together to provide a cooling fan relay with a uninterrupted switched 12v source. This method of connection will be used when you are controlling the cooling fan with a thermostatic switch which switches ground to the relay to turn the fans off and on.

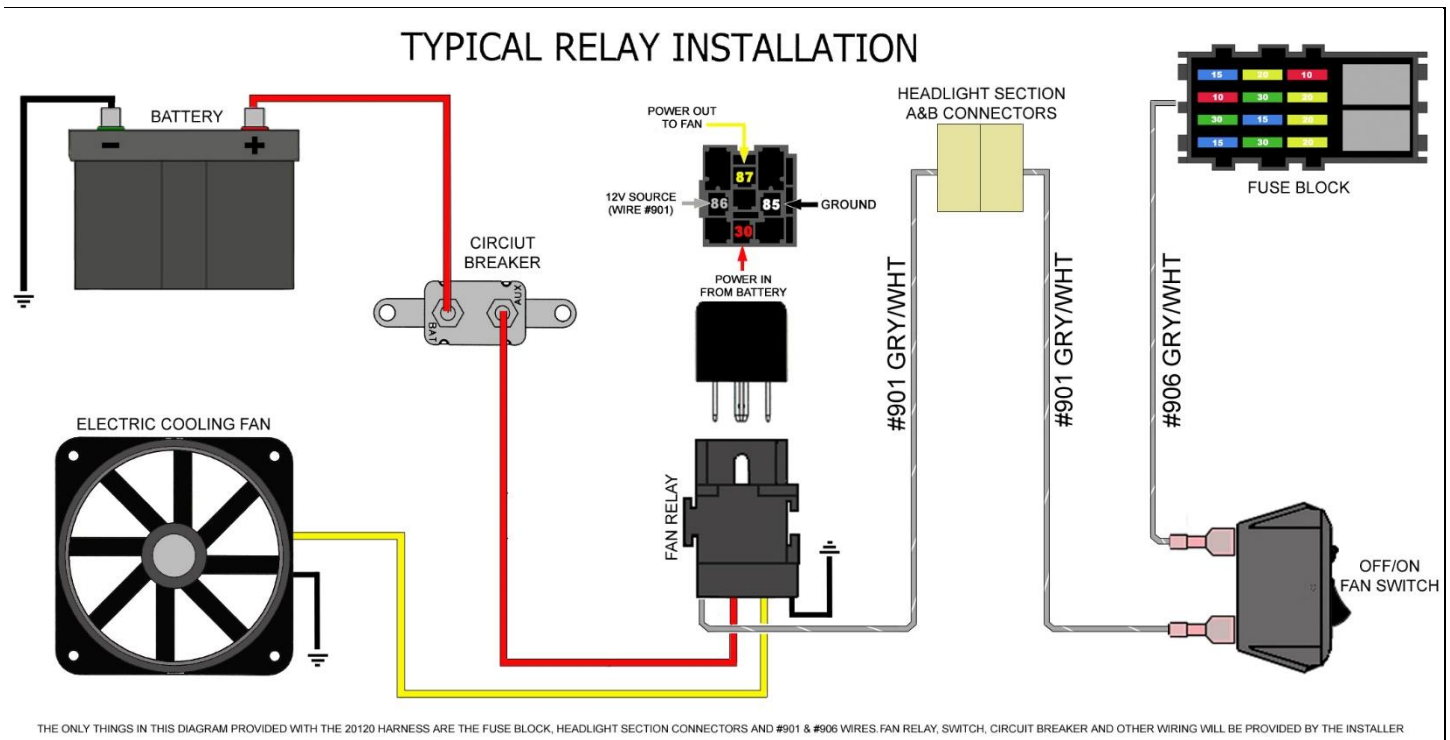

Figure 26 Typical Fan Relay Installation

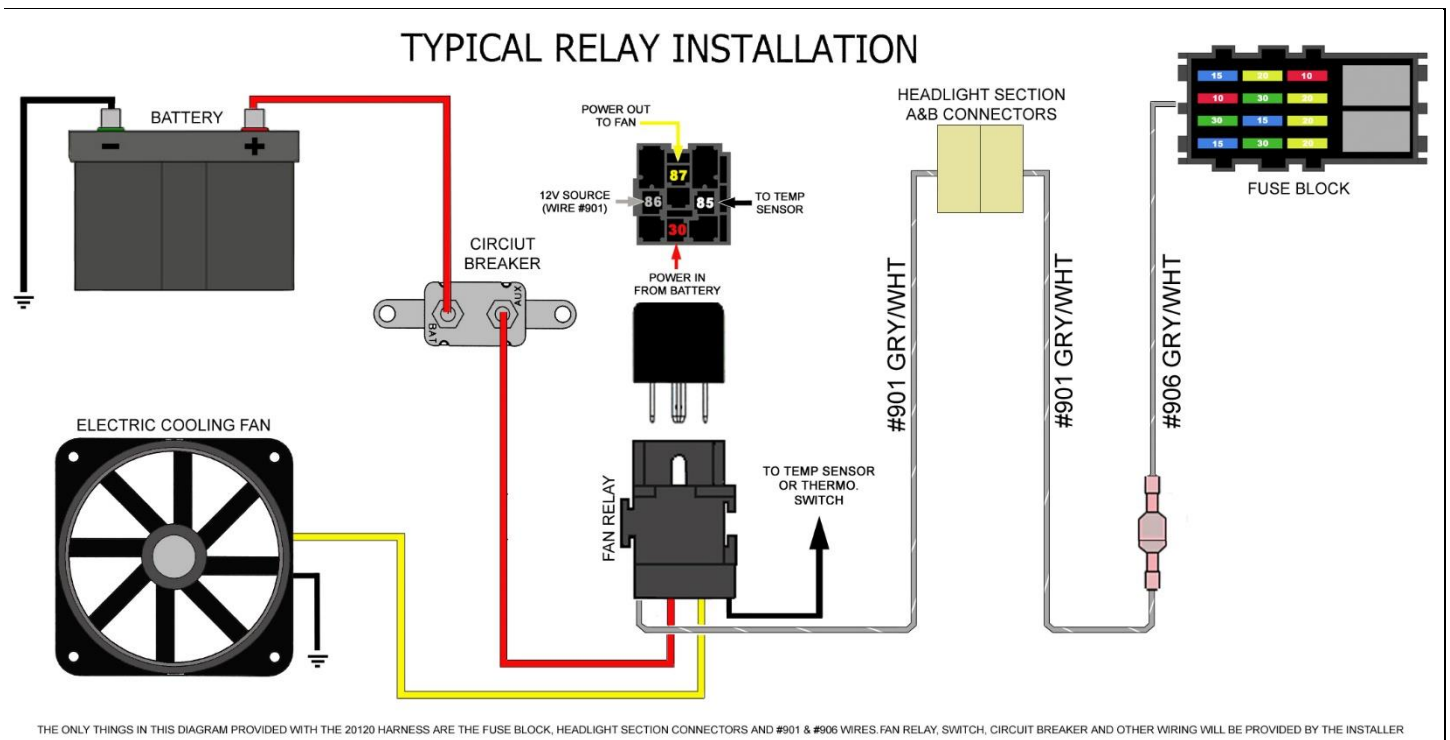

Figure 27 Fan relay installation using thermostatic switch (ground activation)

Headlight Switch

- Connect these wires of the Headlight Switch according to **Figure 28**. All Headlight Switch wires are terminated with the correct terminals to fit the original Headlight Switch connector housing. Repeat the procedure for terminal removal and installation discussed in **Section 7.9.1**.

Note: Terminal positions A, D1, D2, and H are turned 180° from positions B, I, R and P.

Designation	Painless Wire Color	Terminal
Fuse Block	928 Blk/Org	B
Interior Lights	918 Lt.Grn/Ylw	D1
Courtesy Lights	945 Blk/Blu	D2
Dimmer Switch	907 Red/Ylw	H
Gauge Lights	931 Lt.Blu/Red	I
Front Park Lights	926 Blk/Ylw	P
Tail Lights	929 Blk	R

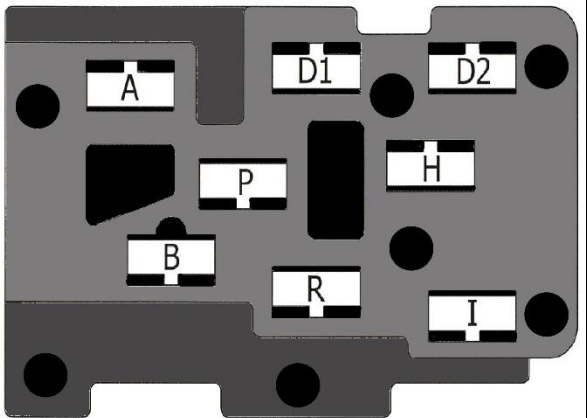

Figure 28 Headlight Switch Connector Housing Wiring (Wire Side View)

Dimmer Switch

Dimmer switch wiring comes pre-terminated with a connector installed. This connector and attached wiring will need to run under the carpet and connected to the Dimmer Switch.

Accessory Relay

A 20amp Accessory Relay is provided at the Fuse block; it is not fused and uses 14 gauge input/output wires and 18 gauge activation/ground wires. It can be used as a GROUND or POWER activation Relay. The component being powered using this relay must not exceed a constant amperage of 20 amps.

12V Activation

A 12 volt activated relay is constantly grounded and will send power out of the output side of the relay to the component being powered when 12 volts is applied to the relay, as the name implies. The 12 volt source can be wired directly to the relay or interrupted by a switch, as shown by wire #997 (ylw/blk) in **Figure 29**.

Wiring directly to the relay would be used in the case of wiring an electric fuel pump or any other high amperage component you would want to run continuously while the key is in the on position. In these cases, make certain the 12 volt wire you are using is a Switched 12 volt wire and not a battery constant.

The 12 volt activation wire can also be wired to a switch to offer the user OFF/ON capabilities. These are the situations a battery constant power source would be used. This would allow a component to be turned OFF or ON with out the key in the ON position. However, unless a

lighted switch is being used, a ground activated relay may work better to avoid running power through the switch.

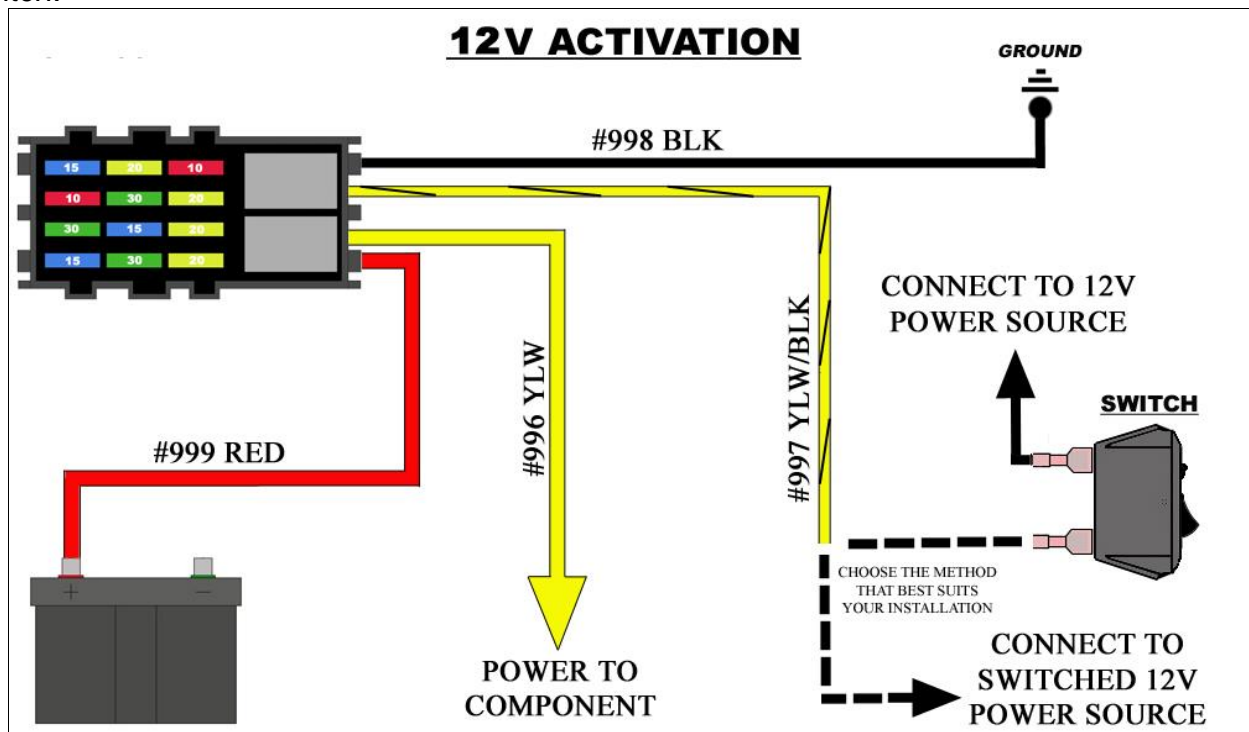

Figure 29 12V Relay Activation

Ground Activation

A ground activated relay is just the opposite of the 12 volt activated relay, 12 volts (battery constant or switched) is supplied uninterrupted and the ground wire is switched. One example of this method is a thermostat operated fan relay. In this case however, a thermostatic switch would replace the switch in the drawing below. Like mentioned before, ground activation method is best used when a component is operated by an unlit switch from the interior of the vehicle.

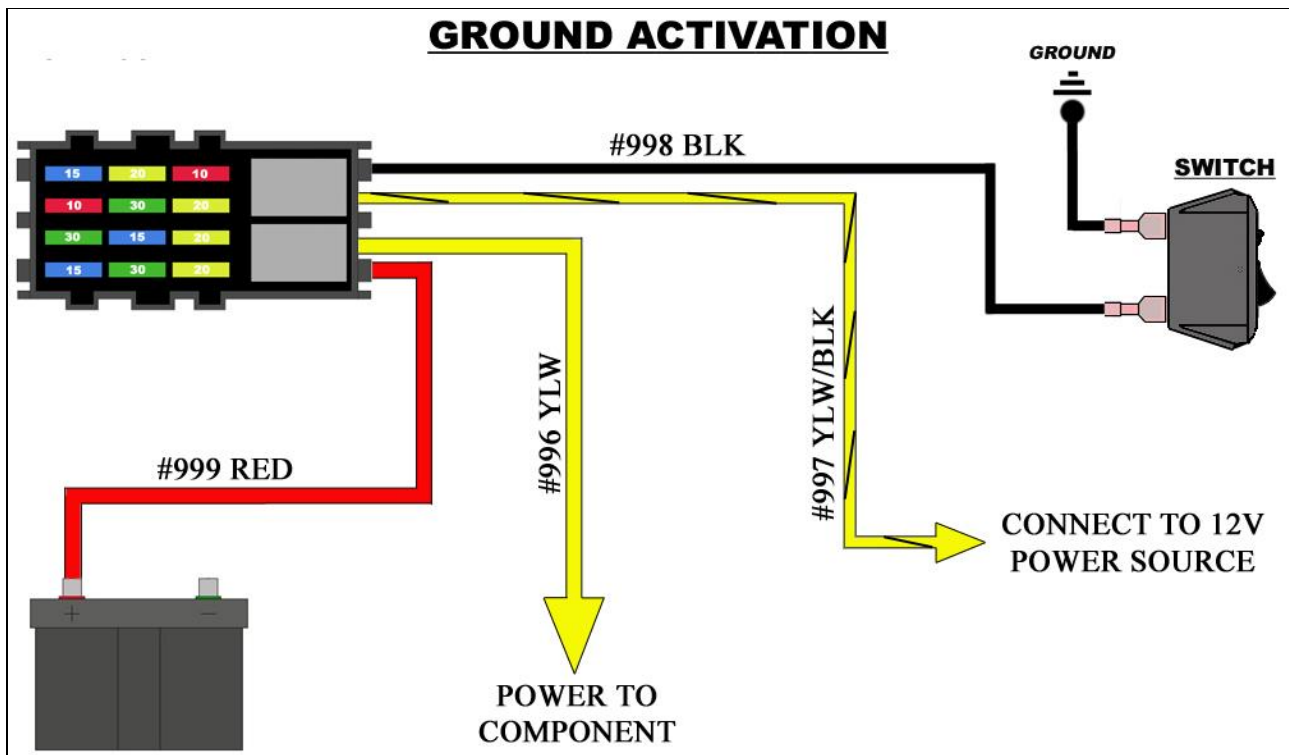

Figure 30 Ground Relay Activation

- Connect wire #996 (ylw) from the relay to the component that you will be powering.
- Connect wire #997 (ylw/blk) from the relay to the switch/button or 12 volt source.
- Connect wire #998 (blk) from the relay to the switch/button or to a grounding point.
- Connect wire #999 (red) from the relay to a Battery power source.

Tail Section Wiring

- Connect the wires in the TAIL SECTION according to **Figure 31**.
- Connect wire #945 (blk/blu) to the left and right rear Courtesy Lamps if applicable, insulate the end and stow the wires out of the way if you do not have rear courtesy lamps.
- Connect wire #939 (ylw) to the Fuel Tank Sending Unit, this wire controls the Fuel Gauge.
- Connect wire #948 (org/blu) to the right rear Turn Lamp, this is the "brighter" element on dual element bulbs. Connect wire #949 (lt.grn/red) to the left rear Turn Lamp, this is the "brighter" element on dual element bulbs. Connect wire #929 (blk) to both Tail Lamps, this is the "dimmer" element on dual element bulbs and to the License Plate Lamp.
- Connect wire # 991 (pur) to both of the Reverse Lamps, this wire supplies power from the Back up Switch. Connect wire #980 (red/blk) to the ground side of the Reverse Lamps and to a chassis ground near the trunk latch.
- When you have Integrated Brake Lights on your vehicle the Turn Signal switch acts as a brain to control when the Lights in the rear are on constantly (braking) or flashing (turning) or a combination of both. **The Turn Signal switch you use must be built to do this! If you are using a steering column out of a salvage yard that was originally in a vehicle that had separate Brake Lights then the switch will not work for Integrated Brake Lights.**
- Almost all light bulbs get the ground they need through the socket housing. If you mount your socket housing into anything other than a grounded metal part then you will need to provide a separate ground wire.

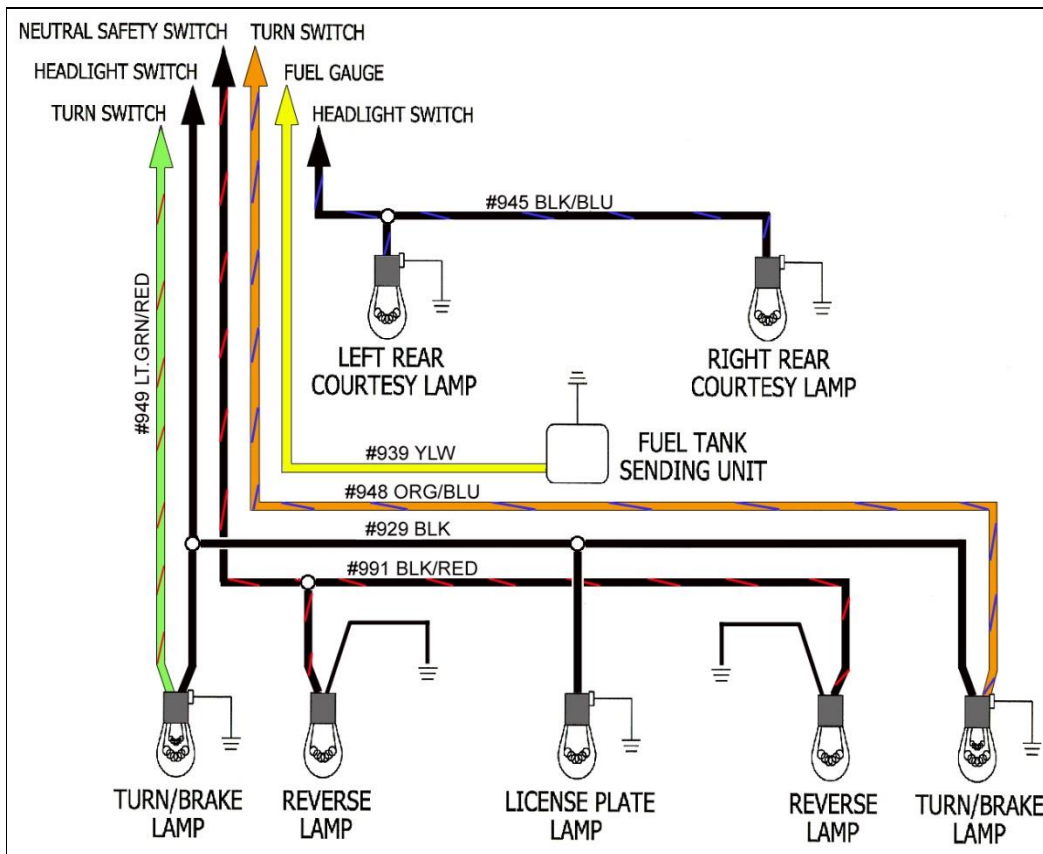

Figure 31 Tail Section Wiring

Testing The Systems

- Use a small (10 amp or less) battery charger to power up the vehicle for circuit testing. If there is a problem anywhere, the battery charger's low amperage and internal circuit breaker will provide circuit protection.
- Connect the battery charger's **NEGATIVE** output to the automobile chassis or engine block and its **POSITIVE** output to the automobile's positive battery terminal.
- **INDIVIDUALLY** turn on each light, ignition, wiper circuit, etc. and check for proper operation.

Note: The turn signals will not flash properly if you do not have both the front and rear bulbs installed and connected.

- When all circuits check out **THEN** attach the battery cable to the battery for vehicle operation.

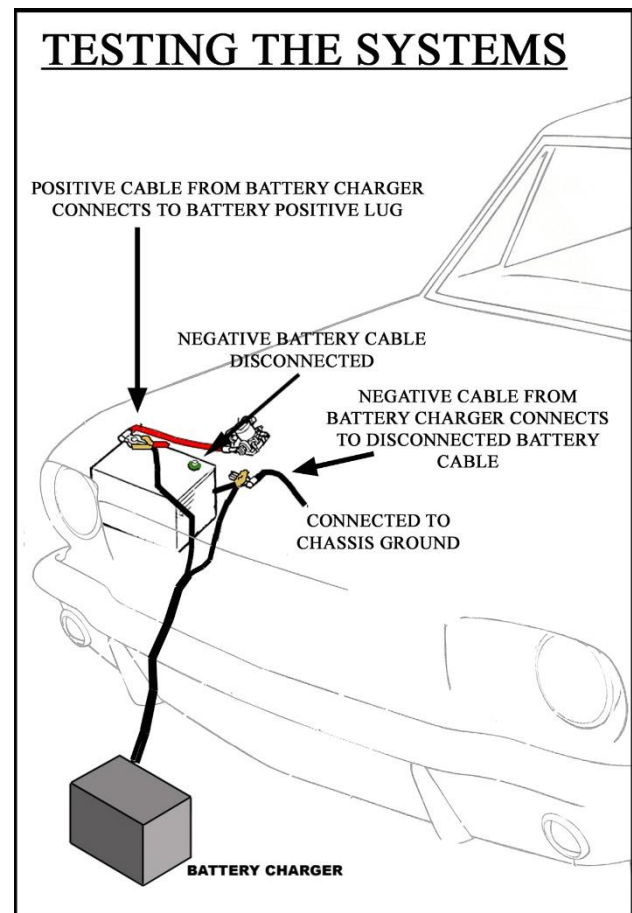

FUSE REQUIREMENTS AND WIRE CONNECTION INDEX

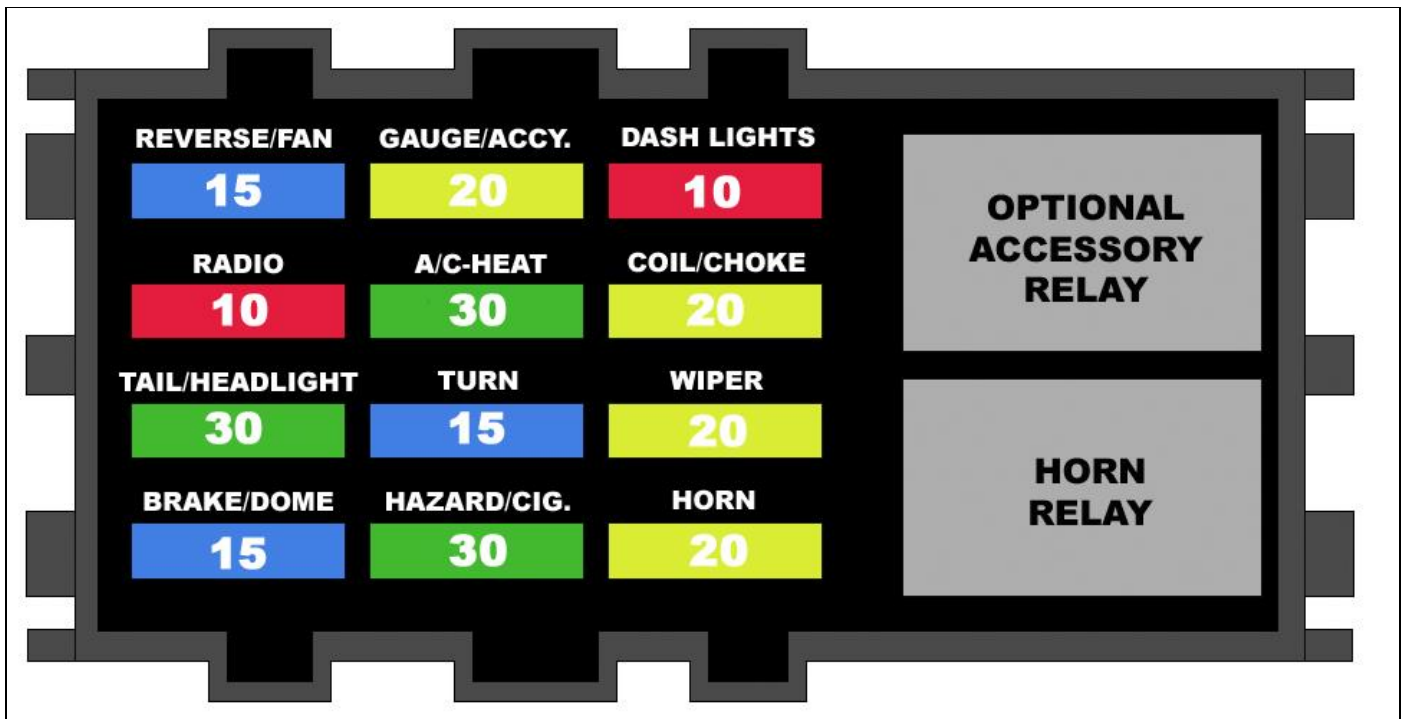

Figure 33 Fuse Requirements

Wire Connection Index

The **Wire Index** is listed in the same order components were listed in this manual. The index is divided vertically into 6 columns. COLOR, GAUGE, CIRCUIT #, FUNCTION, ORIGIN (where the wire comes from), and TERMINAL (lists if the wire comes pre-terminated)

The column labeled CIRCUIT #. contains a 900-series number that is used to identify various wires in the wiring diagrams that are a part of these instructions. Only printed wires will have a 900-series number. The majority of those without a number are pre-terminated and have a connector installed.

HEADLIGHT SECTION B

WASHER PUMP

COLOR	GAUGE	Circuit #	FUNCTION	ORIGIN	TERMINATED
BLK/WHT	16	968	WASHER B+	WIPER SWITCH	NO

VOLTAGE REGULATOR

COLOR	GAUGE	Circuit #	FUNCTION	ORIGIN	TERMINATED
WHT/BLK	14	972	IGN VOLTAGE	GAUGE CLUSTER	YES
WHT	14	970	ALTERNATOR FIELD	ALTERNATOR	YES
YLW	14	913	ALTERNATOR OUTPUT	ALTERNATOR	YES
GRN/RED	14	915	ALTERNATOR STATOR	ALTERNATOR	YES
BLK/RED	14	981	ALTERNATOR GROUND	ALTERNATOR	YES

COOLING FAN RELAY

COLOR	GAUGE	Circuit #	FUNCTION	ORIGIN	TERMINATED
GRY/WHT	18	901	12 VOLT SOURCE/ACTIVATION	COOLING FAN SWITCH	NO

LEFT TURN / PARK

COLOR	GAUGE	Circuit #	FUNCTION	ORIGIN	TERMINATED
GRN/WHT	16	943	TURN SIGNAL B+	TURN SWITCH	YES
BLK/YLW	18	926	PARK LIGHT B+	HEADLIGHT SWITCH	YES
BLK	16	-	GROUND	DRIVER SIDE GROUND	NO

LEFT HEADLIGHT

COLOR	GAUGE	Circuit #	FUNCTION	ORIGIN	TERMINATED
GRN/BLK	14	908	HIGH BEAM B+	DIMMER SWITCH	YES
RED/BLK	14	-	LOW BEAM B+	DIMMER SWITCH	YES
BLK	14	-	GROUND	DRIVER SIDE GROUND	YES

DRIVER SIDE GROUND

COLOR	GAUGE	Circuit #	FUNCTION	ORIGIN	TERMINATED
BLK	12	-	GROUND	LEFT HEADLIGHT / TURN	YES

HORNS

COLOR	GAUGE	Circuit #	FUNCTION	ORIGIN	TERMINATED
YLW/GRN	16	-	LEFT HORN B+	HORN RELAY	YES
YLW/GRN	16	924	RIGHT HORN B+	HORN RELAY	YES

RIGHT HEADLIGHT

COLOR	GAUGE	Circuit #	FUNCTION	ORIGIN	TERMINATED
GRN/BLK	14	908	HIGH BEAM B+	DIMMER SWITCH	YES
RED/BLK	14	909	LOW BEAM B+	DIMMER SWITCH	YES
BLK	14	-	GROUND	PASS. SIDE GROUND	YES

RIGHT TURN / PARK

COLOR	GAUGE	Circuit #	FUNCTION	ORIGIN	TERMINATED
WHT/BLU	16	925	TURN SIGNAL B+	TURN SWITCH	YES
BLK/YLW	18	926	PARK LIGHT B+	HEADLIGHT SWITCH	YES
BLK	16	-	GROUND	PASS. SIDE GROUND	NO

PASSENGER SIDE GROUND

COLOR	GAUGE	Circuit #	FUNCTION	ORIGIN	TERMINATED
BLK	12	-	GROUND	RIGHT HEADLIGHT / TURN	YES

ALTERNATOR

COLOR	GAUGE	Circuit #	FUNCTION	ORIGIN	TERMINATED
WHT	14	970	ALTERNATOR FIELD	VOLTAGE REGULATOR	NO
YLW	14	913	ALTERNATOR OUTPUT	BATTERY	NO
GRN/RED	14	915	ALTERNATOR STATOR	VOLTAGE REGULATOR	NO
BLK/RED	14	981	ALTERNATOR GROUND	VOLTAGE REGULATOR	NO

ENGINE SECTION

MAXI FUSE

COLOR	GAUGE	Circuit #	FUNCTION	ORIGIN	TERMINATED
BLK	10	916	B+ INTO MAXI FUSE	STARTER SOLENOID	NO
BLK	10	916	B+ OUT TO FUSE BLOCK	FUSE BLOCK	NO
RED	16	-	AMMETER	AMMETER	NO

STARTER SOLENOID

COLOR	GAUGE	Circuit #	FUNCTION	ORIGIN	TERMINATED
BLK	10	916	B+ TO MAXI FUSE	MAXI FUSE	NO
RED/BLU	16	919	START SIGNAL	NEUTRAL SAFETY SWITCH	NO
BRN	16	970	IGNITION BYPASS	COIL	NO

COIL

COLOR	GAUGE	Circuit #	FUNCTION	ORIGIN	TERMINATED
RED/GRN	16	920	COIL B+	FUSE BLOCK	NO
GRN	18	923	AFTERMARKET TACH. SIGNAL	RADIO / TACH SECTION	NO
BRN	16	970	IGNITION BYPASS	STARTER SOLENOID	NO

BLOWER MOTOR

COLOR	GAUGE	Circuit #	FUNCTION	ORIGIN	TERMINATED
BRN	14	904	DEPENDS ON SYSTEM USED (REFER TO FIGURES 23 & 24)		NO
YLW	16	903			NO

NEUTRAL SAFETY / REVERSE

COLOR	GAUGE	Circuit #	FUNCTION	ORIGIN	TERMINATED
RED/BLU	16	919	START SIGNAL TO SOLENOID	STARTER SOLENOID	NO
RED/BLU	16	919	START SIGNAL FROM IGN. SWITCH	IGNITION SWITCH	NO
BLK/RED	16	953	B+ FROM FUSE BLOCK	FUSE BLOCK	NO
BLK/RED	16	991	B+ OUT TO REVERSE LIGHTS	REVERSE LIGHTS	NO

GAUGE SENDING UNITS

COLOR	GAUGE	Circuit #	FUNCTION	ORIGIN	TERMINATED
RED/WHT	18	921	COOLANT TEMP	GAUGE CLUSTER	NO
WHT/RED	18	922	OIL PRESSURE	GAUGE CLUSTER	NO

ACCESSORIES

COLOR	GAUGE	Circuit #	FUNCTION	ORIGIN	TERMINATED
BLK/WHT	16	902	A/C COMPRESSOR AVTIVATION	A/C SWITCH	NO
WHT	16	954	ELECTRIC CHOKE B+	FUSE BLOCK	NO
BLU/YLW	16	986	IDLE SOLENOID B+	FUSE BLOCK	NO

INTERIOR SECTION

STEERING COLUMN

COLOR	GAUGE	Circuit #	FUNCTION	ORIGIN	TERMINATED
ORG/BLU	16	948	RIGHT REAR TURN/BRAKE B+	RIGHT TURN / BRAKE	YES
GRN/ORG	16	949	LEFT REAR TURN/BRAKE B+	LEFT TURN / BRAKE	YES
WHT/BLU	16	-	RIGHT FRONT TURN B+	RIGHT TURN / PARK	YES
BLK/RED	8	-	HORN RELAY ACTIVATION	HORN RELAY	YES
GRN/WHT	16	-	LEFT FRONT TURN B+	LEFT TURN / PARK	YES
GRN	16	982	HAZARD SWITCH INPUT (BRAKE)	HAZARD SWITCH	YES
GRN	16	982	BRAKE SWITCH INPUT	BRAKE SWITCH	YES
YLW	14	-	B+ TO HORN BUTTON	FUSE BLOCK	YES
LT.BLU	16	952	TURN FLASHER INPUT	TURN FLASHER	YES

IGNITION SWITCH

COLOR	GAUGE	Circuit #	FUNCTION	ORIGIN	TERMINATED
RED/BLU	16	919	START SIGNAL	NEUTRAL SAFETY SWITCH	YES
YLW	10	933	B+ INPUT	BATTERY	YES
BLK/ORG	10	932	B+ OUTPUT	FUSE BLOCK	YES
GRY/BLK	16	-	ACCESSORY OUTPUT	FUSE BLOCK	YES

LEFT DOOR JAMB SWITCH

COLOR	GAUGE	Circuit #	FUNCTION	ORIGIN	TERMINATED
LT.GRN/YLW	18	-	B+ INPUT	FUSE BLOCK	YES
BLK/BLU	18	945	B+ OUTPUT	INTERIOR LIGHTS	YES

LEFT DOOR / COURTESY LIGHT

COLOR	GAUGE	Circuit #	FUNCTION	ORIGIN	TERMINATED
BLK/BLU	16	-	B+	HEADLIGHT SWITCH	YES

CONSOLE LEADS

COLOR	GAUGE	Circuit #	FUNCTION	ORIGIN	TERMINATED
LT.GRN/YLW	18	918	CONSOLE COMPARTMENT LIGHT B+	HEADLIGHT SWITCH	YES
BLK/BLU	18	945	CONSOLE COURTESY LIGHT B+	HEADLIGHT SWITCH	YES

GLOVE BOX LAMP

COLOR	GAUGE	Circuit #	FUNCTION	ORIGIN	TERMINATED
LT.GRN/YLW	18	-	B+	HEADLIGHT SWITCH	YES

RIGHT DOOR / COURTESY LIGHT

COLOR	GAUGE	Circuit #	FUNCTION	ORIGIN	TERMINATED
BLK/BLU	16	-	B+	HEADLIGHT SWITCH	YES

RIGHT DOOR JAMB SWITCH

COLOR	GAUGE	Circuit #	FUNCTION	ORIGIN	TERMINATED
LT.GRN/YLW	18	-	B+ INPUT	FUSE BLOCK	YES
BLK/BLU	18	945	B+ OUTPUT	INTERIOR LIGHTS	YES

BRAKE SWITCH

COLOR	GAUGE	Circuit #	FUNCTION	ORIGIN	TERMINATED
LT.GRN/RED	16	917	B+ INPUT	FUSE BLOCK	NO
GRN	16	982	B+ OUTPUT	TURN SIGNAL SWITCH	NO

INSTRUMENT PANEL

COLOR	GAUGE	Circuit #	FUNCTION	ORIGIN	TERMINATED
BLK/GRN	14	935	CHARGE IND. INPUT	FUSE BLOCK	YES
WHT/BLK	14	-	CHARGE IND. OUTPUT	ALTERNATOR	YES
RED/WHT	18	921	COOLANT TEMP SIGNAL	COOL. TEMP SENDING UNIT	YES
WHT/BLU	18	-	RIGHT TURN INDICATOR	TURN SWITCH	YES
BLK	16	-	GROUND	GROUND	YES
GRN/WHT	18	-	LEFT TURN INDICATOR	TURN SWITCH	YES
LT.BLU/RED	18	-	BACK LIGHTING	HEADLIGHT SWITCH	YES
GRN/BLK	18	908	HIGH BEAM INDICATOR	DIMMER SWITCH	YES
LT.GRN/RED	18	-	GAUGE B+	FUSE BLOCK	YES
YLW	18	939	FUEL GAUGE SIGNAL	FUEL SENDING UNIT	YES
WHT/RED	18	922	OIL PRESSURE SIGNAL	OIL PRESS. SENDING UNIT	YES
YLW	16	-	AMMETER IN	BATTERY	NO
RED	16	-	AMMETER OUT	FUSE BLOCK	NO

WIPER SWITCH

COLOR	GAUGE	Circuit #	FUNCTION	ORIGIN	TERMINATED
ORG/WHT	16	905	B+	FUSE BLOCK	YES
BLK/WHT	16	908	B+ OUT TO WASHER PUMP	WASHER PUMP	YES

HAZARD SWITCH

COLOR	GAUGE	Circuit #	FUNCTION	ORIGIN	TERMINATED
LT.BLU			B+ FROM HAZARD FLASHER	HAZARD FLASHER	NO
GRN/WHT			LEFT TURN	TURN SWITCH	NO
GRN			BRAKE SWITCH INPUT	TURN SWITCH	NO
WHT/BLU			RIGHT TURN	TURN SWITCH	NO

HEATER - A/C SWITCH

COLOR	GAUGE	Circuit #	FUNCTION	ORIGIN	TERMINATED
YLW	16	903	DEPENDS ON SYSTEM (REFER TO FIGURES 23 & 24)		NO
BRN	14	904			NO
BLK/WKT	14	900			NO
BLK/WHT	16	-	A/C SWITCH B+	FUSE BLOCK	NO
BLK/WHT	16	902	A/C COMPRESSOR ACTIVATION	A/C COMPRESSOR	NO

COOLING FAN SWITCH

COLOR	GAUGE	Circuit #	FUNCTION	ORIGIN	TERMINATED
GRY/WHT	18	901	B+ OUT TO FAN RELAY	COOLING FAN RELAY	NO
GRY/WHT	18	906	B+ FROM FUSE BLOCK	FUSE BLOCK	NO

HEADLIGHT SWITCH

COLOR	GAUGE	Circuit #	FUNCTION	ORIGIN	TERMINATED
BLK/ORG	12	928	B+ INPUT	FUSE BLOCK	YES
LT.GRN/YLW	18	-	COURTESY LIGHT B+ INPUT	FUSE BLOCK	YES
BLK/BLU	14	945	B+ OUTPUT TO COURTESY LIGHTS	COURTESY LIGHTS	YES
RED/YLW	14	904	B+ OUTPUT TO DIMMER SWITCH	DIMMER SWITCH	YES
LT.BLU/RED	18	931	B+ OUTPUT TO GAUGE LIGHTING	GAUGE CLUSTER	YES
BLK/YLW	16	926	B+ OUTPUT TO PARK LIGHTS	FRONT PARK LIGHTS	YES
BLK	16	929	B+ OUTPUT TO TAIL LIGHTS	TAIL LIGHTS	YES

DIMMER SWITCH

COLOR	GAUGE	Circuit #	FUNCTION	ORIGIN	TERMINATED
GRN/BLK	14	908	HIGH BEAM OUTPUT	HEADLIGHTS	YES
GRN/BLK	18	908	HIGH BEAM INDICATOR	GAUGE CLUSTER	YES
RED/BLK	14	909	LOW BEAM OUTPUT	HEADLIGHTS	YES
RED/YLW	14	907	B+ INPUT	HEADLIGHT SWITCH	YES

ACCESSORY RELAY

COLOR	GAUGE	Circuit #	FUNCTION	ORIGIN	TERMINATED
YLW/BLK	18	997	ACTIVATION	FUSE BLOCK	NO
BLK	18	998	GROUND	FUSE BLOCK	NO
YLW/BLK	14	996	OUTPUT	FUSE BLOCK	NO
RED	14	999	INPUT	FUSE BLOCK	NO

CIG. LIGHTER / POWER PORT

COLOR	GAUGE	Circuit #	FUNCTION	ORIGIN	TERMINATED
YLW	14	995	B+	FUSE BLOCK	NO

RADIO

COLOR	GAUGE	Circuit #	FUNCTION	ORIGIN	TERMINATED
RED	16	941	IGN B+	FUSE BLOCK	NO
YELLOW	18	940	BATTERY B+	FUSE BLOCK	NO

TAIL SECTION**PILLAR LIGHTS**

COLOR	GAUGE	Circuit #	FUNCTION	ORIGIN	TERMINATED
BLK/BLU	18	945	B+	HEADLIGHT SWITCH	NO
BLK/BLU	18	-	B+	HEADLIGHT SWITCH	NO

FUEL SENDING UNIT

COLOR	GAUGE	Circuit #	FUNCTION	ORIGIN	TERMINATED
YLW	18	939	FUEL GAUGE SIGNAL	GAUGE CLUSTER	NO

LEFT REVERSE LAMP

COLOR	GAUGE	Circuit #	FUNCTION	ORIGIN	TERMINATED
BLK/RED	16	-	REVERSE LIGHT B+	REVERSE SWITCH	NO

LEFT TAIL LAMP

COLOR	GAUGE	Circuit #	FUNCTION	ORIGIN	TERMINATED
BLK	16	-	TAIL LIGHT B+	HEADLIGHT SWITCH	YES
GRN/ORG	18	949	LEFT TURN / BRAKE B+	TURN SIGNAL SWITCH	YES

LICENSE PLATE LAMP

COLOR	GAUGE	Circuit #	FUNCTION	ORIGIN	TERMINATED
BLK	16	-	B+	HEADLIGHT SWITCH	NO

RIGHT REVERSE LAMP

COLOR	GAUGE	Circuit #	FUNCTION	ORIGIN	TERMINATED
BLK/RED	16	991	REVERSE LIGHT B+	REVERSE SWITCH	NO

RIGHT TAIL LAMP

COLOR	GAUGE	Circuit #	FUNCTION	ORIGIN	TERMINATED
BLK	16	929	TAIL LIGHT B+	HEADLIGHT SWITCH	YES
ORG/BLU	18	948	RIGHT TURN / BRAKE B+	TURN SIGNAL SWITCH	YES

If you have any questions concerning the installation of this harness or having trouble in general, feel free to call Painless Performance Products' tech line at 1-800-423-9696. Calls are answered from 8am to 5pm central time, Monday thru Friday, except holidays.

We have attempted to provide you with as accurate instructions as possible, and are always concerned about corrections or improvements that can be made. If you have found any errors or omissions, or if you simply have comments or suggestions concerning these instructions, please write us at the address on the cover and let us know about them. Or, better yet, send us a fax at (817) 244-4024 or e-mail us at painless@painlessperformance.com.

We sincerely appreciate your business.

OTHER PAINLESS PARTS

The following list contains other Painless part numbers that could be applied to your Mustang install.

PAINLESS PART #

PART DESCRIPTION

70920

Chassis Harness Power Braid Kit

Replacement Harnesses

30812

Duraspark II Harness

60510

Ford 5.0L Fuel Injection Harness

60511

Extra Length Fuel Injection Harness

65250

1985-1993 Ford 5.0L Engine Management System

65251

1994-1995 Ford 5.0L Engine Management System

Accessories

30100

70 Amp Relay

30104

Adjustable Electric Fan Thermostat Kit

30107

3-Pack Relay Bank

30108

6-Pack relay Bank

30130

Weatherproof Electric Fan Relay

30131

Weatherproof Fuel Pump Relay

30803

Auxiliary Light Relay Kit

30815

Halogen Headlight Harness

80102

Replacement Maxi Fuse

Painless also offers a full lineup of Toggle & Rocker Switches, Switch Panels, Weatherproof Connectors, Battery Cables, Bulk wire and Terminals. Check out our full catalog on the web at www.painlessperformance.com for more products and full product descriptions of the parts listed above.

NOTES

Painless Performance Limited Warranty and Return Policy

Chassis harnesses and fuel injection harnesses are covered under a lifetime warranty.

All other products manufactured and/or sold by Painless Performance are warranted to the original purchaser to be free from defects in material and workmanship under normal use. Painless Performance will repair or replace defective products without charge during the first 12 months from the purchase date. No products will be considered for warranty without a copy of the purchase receipt showing the sellers name, address and date of purchase. You must return the product to the dealer you purchased it from to initiate warranty procedures.